

HUMAN POWER

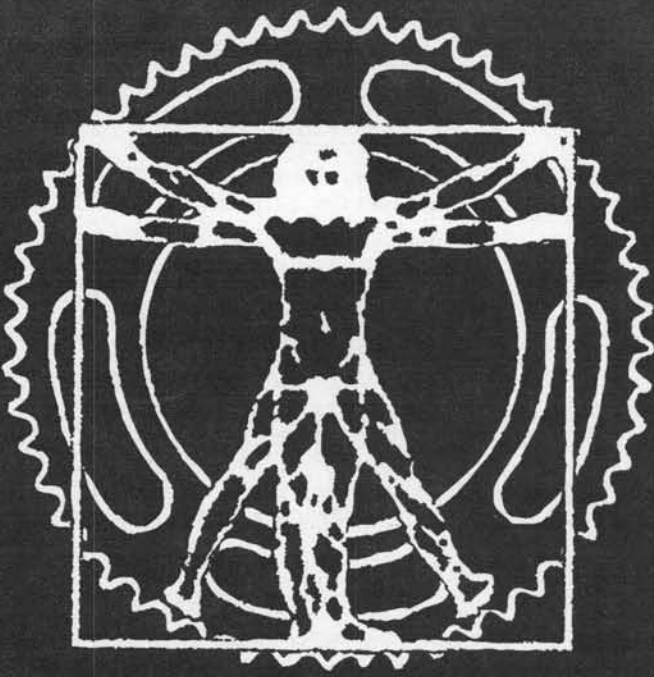

TECHNICAL JOURNAL OF THE IHPVA

ISSUE NO. 40
CONTENTS OF VOL. 12 NO. 1

Summaries of articles in this issue, and masthead	2
Rowing-action bicycles: success and uncertainty <i>Ben Wichers Schreur, and John Martinson</i>	3
Recumbent-tricycle design <i>Allen E. Armstrong</i>	5
Systems design of the Dragonfly: a human-powered helicopter <i>Andrew Cary, Tim Morthland & Eric Loth</i>	9
Reviews	
RCN Buyers' Guide Cycling Today <i>Dave Wilson</i>	15
Octogenarian cyclist <i>W.R.E. "Ron" Beams</i>	16
Letters	
Is it an EHPV or an EPV? <i>John G. Tetz</i>	17
AHPVs: a plea for agreement <i>Theo Schmidt</i>	18
Stirling engines <i>Peter Ernst</i>	19
Book reviews	
The space-frame Moultons, by Tony Hadland Pedalling unknown paths, by Michèle Velthuisen-de Vries <i>Dave Wilson</i>	20
Technical note	
The Daedalus HPA: why shaft drive? <i>Jean-Joseph Cote</i>	21
Correction	
Vehicle dragxarea (CdA): a table in "The unfair advantage" <i>Martin Staubach</i>	22
Editorials	
Following the surf; the wheel extended; publication frequency <i>Dave Wilson</i>	23

Human Power

The technical journal of the
International Human-Powered Vehicle
Association

David Gordon Wilson, editor
21 Winthrop Street

Winchester, MA 01890-2851, USA

Phones: 617-729-2203 (home)
617-253-5121 (MIT); 617-258-6149 (FAX)
dgwilson@mit.edu (email)

Associate editors

Toshio Kataoka, Japan

1-7-2-818 Hiranomiya-Machi
Hirano-ku, Osaka-shi, Japan 547

Theodor Schmidt, Europe

Ortbühlweg 44

CH-3612 Steffisburg, Switzerland

Philip Thiel, watercraft

4720 7th Avenue, NE

Seattle, WA 98105, USA

IHPVA

P.O. Box 51255

Indianapolis, IN 46251, USA

Phone: 317-876-9478; FAX: 317-876-9470

Officers

Marti Daily, president, exec. director

Adam Englund, secretary

Tess Machlin, treasurer

Paul MacCready, int'l president

Nancy Sanford, VP water

Andrew Letton, VP land

Chris Roper, VP air

Matteo Martignoni, VP ATV

Theodor Schmidt, VP hybrid power

Board members

Leonard Brunkalla

Marti Daily

Murray Dowling

Bill Gaines

Al Krause

Chet Kyle

Andrew Letton

Gardner Martin

Dennis Taves

Human Power is published approx.
quarterly by the International Human-
Powered Vehicle Assoc., Inc., a non-profit
organization devoted to the study and ap-
plication of human muscular potential to
propel craft through the air, in and on the
water and on land. Membership informa-
tion is available by sending a self-
addressed stamped business-sized enve-
lope to the IHPVA address above.

Additional copies of *Human Power* may
be purchased by members for \$3.50 each,
and by non-members for \$5.00 each.

Material in *Human Power* is copyrighted
by the IHPVA. Unless copyrighted also
by the author(s), complete articles or rep-
resentative excerpts may be published
elsewhere if full credit to the author(s) and
the IHPVA is prominently given.

We welcome contributions, preferably
on a PC diskette, for *Human Power*. Send
them to the editor at his address above.
He would be happy to send guidelines on
preparing contributions. They should be
of technical or longer-term interest: news
and notices etc. should go to HPV News
editor Leonard Brunkalla at 260 S. Chan-
ning, apt. 1, Elgin, IL 60120-6619.

We are indebted to the authors and to
Marti Daily and her volunteers, whose
dedicated help made this issue possible.

Dave Wilson

In this issue

Rowing-action bicycles: success and uncertainty

Two contrasting reports lead
off this issue: an apparently highly
successful rowing-action bicycle
with which Derk Thijs won the
Paris-Amsterdam race; and the re-
cently introduced commercial Row-
bike of Scott Olson (p. 3).

Recumbent tricycle design

Allen Armstrong, a highly
skilled electro-mechanical engineer,
applies classical design methods to
a recumbent tricycle. The drawings
and photographs are beautiful
(p. 5).

Systems design of the Dragonfly: a human- powered helicopter

The most difficult-to-reach
prize in the human-power field is
that set by the American Helicopter
Society to honor Igor Sikorsky. A
team from the University of Illinois
led by Eric Loth describes the ap-
plication of precise systems engi-
neering to the optimization study.
This predicts that the goal is attain-
able, and the two-rotor HPH is cur-
rently being constructed. (p. 9).

Octogenarian bicyclist

Ron Beams begins his story - of
someone who came late to bicy-
cling, and who designed his own
recumbent tricycles. He rides them
in the company of others who find
that bicycling keeps them enjoying
life long after many couch potatoes
have given up (p. 16).

Shaft drive in the Daedalus aircraft: why there and not in HP land vehicles?

Jean-Joseph Cote, who put in a
great many hours on the HP aircraft
that flew 119 km, responds to your
editor's question: if here, why not
on all HPVs? (p. 21).

Letters - on AHPVs

Assisted HPVs continue to at-
tract a lot of comment. John Tetz
re-iterates his principles of AHPVs,
and believes that a recent paper in
Human Power could have been de-
scribing electrically powered vehi-
cles. Theo Schmidt issues a plea
for agreement on AHPVs so that
they may be included in our races,
and so lead to improvements. Peter
Ernst would like to see Stirling en-
gines developed for AHPVs (p. 17).

Reviews

A labor of love is one
description of Tony Hadland's new
book on the "space-frame Moul-
tons". Also reviewed by your editor
is a book on a remarkable tour of
the U.S. by a Dutch couple, on two
recumbent bicycles. These were
designed and built by the husband,
while the story, "Pedalling un-
known paths", is told by his spouse,
Michele Velthuizen de Vries. The
latest buyers' guide from *Recum-
bent Cyclist News* and a British
magazine "Cycling today" are also
reviewed. (pp. 15 & 20)

Correction

Your editor unwittingly cut off
a large, valuable part of a table on
coast-down tests giving compara-
tive aerodynamic-drag data for dif-
ferent vehicles reported by Martin
Staubach in his paper "The unfair
advantage". The whole table is
given here (p. 22).

Editorials

There are similarities between
the IHPVA and surfing associa-
tions, and we could learn from
them. A Toyota house magazine is
devoted entirely to a favorable dis-
cussion of HPVs. The somewhat
uncertain frequency of publication
of *Human Power* is partly blamed
on the extraordinary uncertainty of
"promising" contributors. These
are the two topics in the editorials
on p. 23.

Dave Wilson

HUMAN POWER

Vol. 12, no. 1

Spring, 1995

\$5.00 (\$3.50 members)

ROWING-ACTION BICYCLES: SUCCESS AND UNCERTAINTY

Two contrasting reports about bicycles propelled by rowing action seem likely to increase interest in this old but still intriguing concept. The first is from the Netherlands, which seems from the beautifully produced publication of the Netherlands HPV association, *hvp nieuws*, to be populated entirely by designers who are not only highly creative but who finish their machines superbly.

Rowing-bike success

This information from an article in the Dutch cycling magazine 'Fiets' was sent out on the Internet by Ben Wichers Schreur who gave me his permission to use it and added other information.

The first HPV Paris-Amsterdam race was won by Derk Thijs on his rowing-action bicycle, which was equipped for the occasion with a Mylar fairing. Derk finished the 560 km in 18 hours, 34 minutes and 59 seconds. He was one hour and a quarter ahead of a group of three triathletes, Ber Heijn, Arend Middelveld and Maurits van der Heyde, who were 25 minutes ahead of Martin Feijen, an ultra-triathlete doing PA as a training ride for a five-fold marathon. Numbers six, seven and eight were also triathletes, Guus Moonen, Gijs Smit and Laurens van den Bosch. These wedge (conventional-bike) riders didn't think much of the self-built faired 'bent that Meijndert Valenteijn, who finished ninth, the last to finish well within 24 hours, was riding. They had to admit though that Meijndert was faster, but finished later because of falls, flats and losing his way. Numbers 10, 11, 12 and 13 were 'bent riders again. The overall impression was that the triathletes were

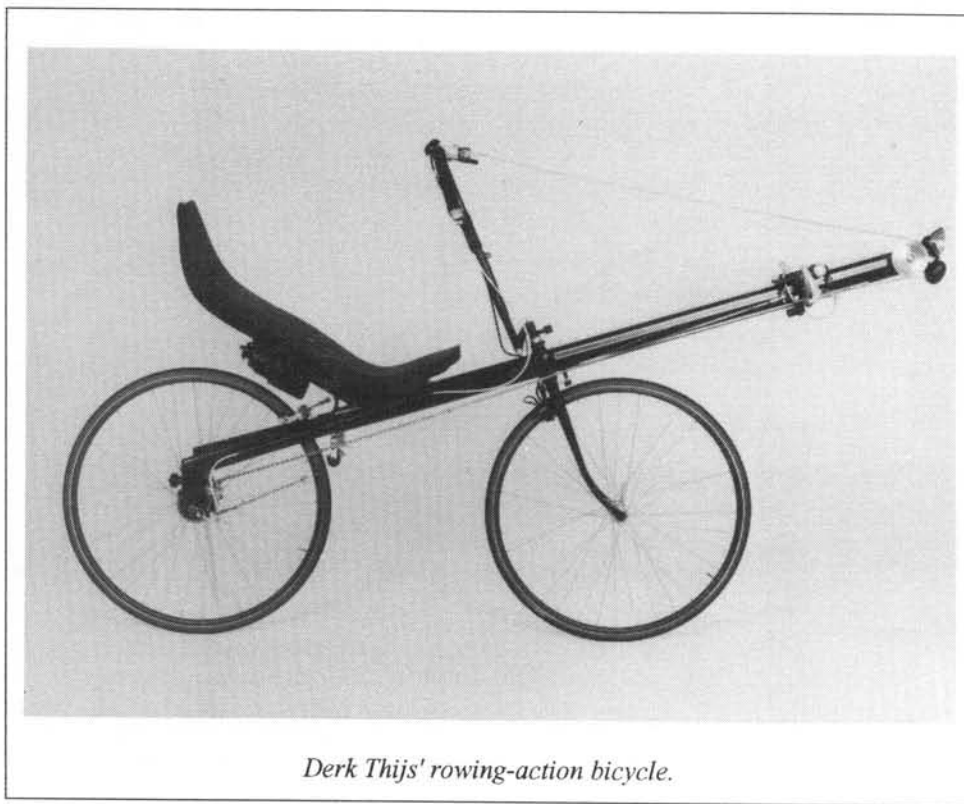

Derk Thijs' rowing-action bicycle.

much better prepared than the 'bent riders. So, is it still an undecided choice between wedgies and 'bents?

Another feat of Derk Thijs: late September he bettered the arm-powered-vehicle world hour record in Bordeaux. He set it at 32.835 km. Martin Feijen set a new world record for the five-fold triathlon on October 8th: 76 hours, 16 minutes and 31 seconds.

The next Paris-Amsterdam race will start at 1800 on September 9, 1995 from the Eiffel Tower. The organizer is Nol Twigt (phone 31 2290 70726).

Derk Thijs' addresses are:
*Thijs I.D., Kookerkstraat 10
4331 AW Middelburg, The Netherlands*
His studio is at
*Schuttershofstraat 5
4331 NZ Middelburg, The Netherlands*
(Phone: 31 1180 34166) (All Dutch telephone numbers will change Oct. 1, '95)

Derk Thijs made a standard rowbike and a low racing version, in addition to funbikes, surf boards, composite wheels, and fairings for Bram Moens' M5 recumbents. The standard rowbike sells for about dfl 4500, about \$2700-\$3000.

Ben Wichers Schreur
Koninklijk Nederlands Meteorologisch
Instituut +31 30 206 617
P.O. Box 201, 3730 AE De Bilt
The Netherlands
ben@knmi.nl

Scott Olson's "Rowbike"

The second report is from John Martinson of the University of Reno, NV.

Since my Rowbike had arrived in Reno, NV I've been learning to ride it. There is a definite learning curve a new owner has to go through. On all bikes

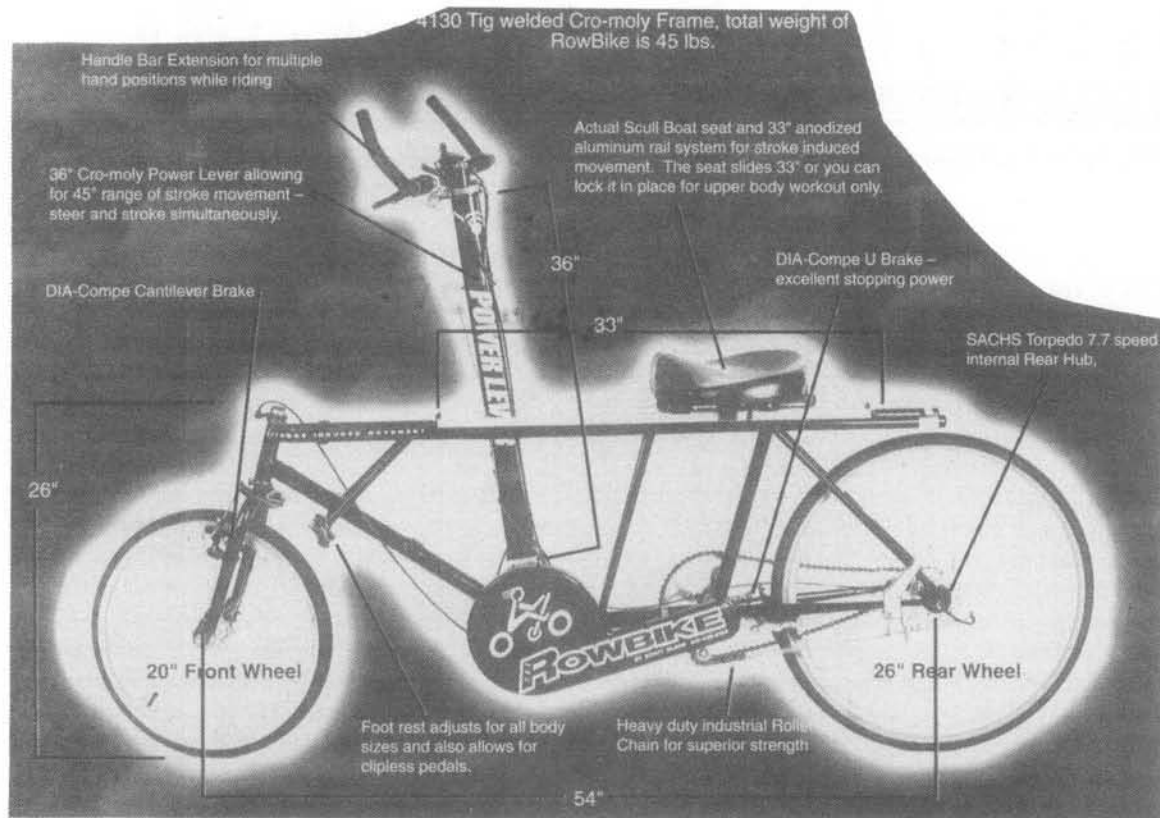

The "Rowbike" by Scott Olson

miracles of modern materials science I've wondered if some kind of Stirling cycle could be packaged in a light-weight form, but you still need a very light-weight fuel. If one had a linear-drive system, however, then a simple oscillating piston rod could give an assist without going through the complexities of turning piston motion into the rotary motion of tires. That's one of the appeals of the Kallander tapered belt for me. It's hard for me to imagine a simpler way to turn linear power into rotary motion. Well, all this is an aside to the experience of the Rowbike, and not anything I'm likely to get involved with for quite a while (if ever).

I thought you might like a personal report on the Rowbike experience. Here are a couple

of other observations. (1) Pulling on the cross piece of the power bar does not readily permit making turn signals since two hands are really required to keep the front wheel straight. (2) Aerodynamically one is handicapped by having the torso in an upright position so much of the time (even though the legs are kept basically horizontal). At the end of the power stroke one can be almost fully reclined with the air flowing over your ventral surface, but it's difficult. And, of course, at no time can you be bent over as the competitive bike riders learn to do most of the time they're in a race.

I am making a similar report to the folks at Rowbike and will update you on their response.

you have to (at least) make it GO, make it STOP, and be able to steer it. All three of these tasks are done quite differently than on a conventional bike and not only have to be learned but have to be integrated. It took me about a half hour to manage even reasonably to propel myself around a mostly empty parking lot. And that's where the manufacturer recommends that you start. Going up even the slightest incline is a formidable task though the folks in Minnesota say that I will master that in time, but I'm dubious. But I'm not too worried since I look on the Rowbike as an excellent full-body exercise machine that provides a much more interesting workout than the rowing machine in the gym. But I doubt that many other people will have such a sanguine attitude about something they purchased as a vehicle.

stroke] we could put power into the "Power Bar" pushing as well as pulling (pulling is all you can do now). And with "forced" motion rather than the "free" motion of the present device we would arrange to have some of the pulling energy stored in a spring to be returned to the drive system on the "pushing" part of the stroke. This would at least provide something like the more continuous motion of a drive sprocket driven alternately by right and left legs. It's the pulsing nature of rowing that I think will be the biggest obstacle the Rowbike people have to overcome. On the flat it's no big problem at all, but going uphill it just exacerbates the problem Paul MacCready has talked about.

As I remember, he says that many more people would use bicycles if they could just have some help in going uphill. I've thought about that problem some, but it's tough to come up with a device so light you don't mind pedaling around with it on the flat, but still have an energy source that can really help you uphill when you need it. With all the

Information on the Olson "Rowbike" can be obtained by phoning 612-442-6155.

John Martinson <marty@unr.edu>

Recumbent-tricycle design

by
Allen E. Armstrong

kilogram heavier than is probably necessary. But the TRYK, as I call it (fig. 1), has had no structural failures in 1500km (900 miles) on the potholed Boston streets.

Vehicle Layout

The vehicle layout is shown in fig. 2. The choice of three wheels rather than four was made to minimize weight and rolling resistance, at the expense of acrobatic capability. One is deprived of the ability to do spectacular spin-outs because the effective track width at the center-of-gravity location is narrow enough that the TRYK will tip over at 0.7g. If there were 4 wheels, this would be over 1.0g.

Given only three wheels, there are a number of things the designer can do to minimize tip-over propensities. Most important is to position the seat as low as possible. The TRYK's seat height is 200 mm, giving a center of gravity (CG) about 300 mm above the road, a result of locating the handlebar and frame tube under the seat. Second is to position the center of gravity as close to the pair of wheels as is consistent with braking requirements (discussed below). The last is to make the track as wide as possible consistent with fitting into an acceptable lane on the road, and getting the vehicle through doors. The definition of "acceptable lane" is somewhat subjective. One standard is the 750-mm maximum width allowable on, e.g., the Dutch bike paths. The TRYK is a bit wide at

Abstract

This paper reports the design logic and results of 1500 km of road testing for a recumbent three-wheeled commuting HPV, built in a home shop.

ferent riding feel: more like driving a formula race car than riding a bike.

The objective of this project was a comfortable longer-distance commuting vehicle. The design emphasizes light weight and low rolling resistance com-

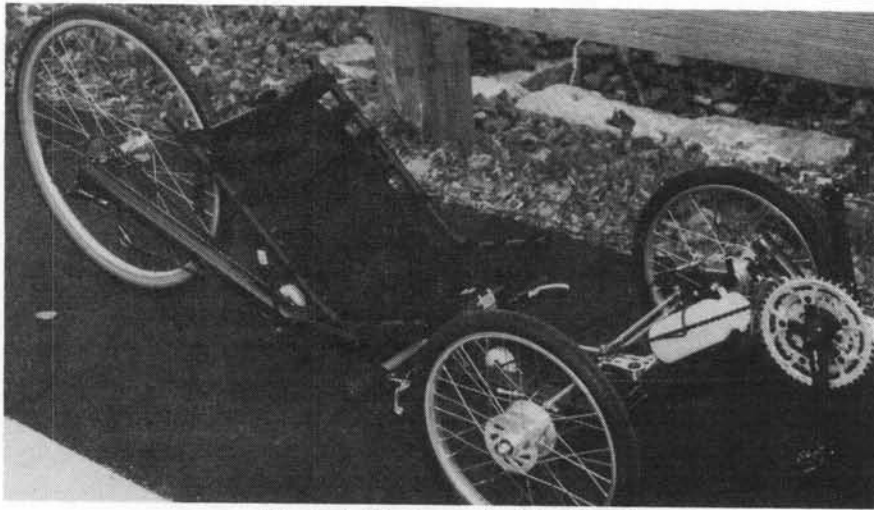

Figure 1 Photograph of the TRYK

Introduction

The upright bicycle's disadvantages in the areas of comfort, safety and wind resistance are compensated, in large part, by its simplicity. Recumbent bicycles offer improvements in these areas, at the cost of increased complexity. In addition, they become more difficult to balance, and to start up from a stop, particularly when clipless pedals are involved. Recumbents also have the problem that the front wheel wants to be where the feet are. To avoid interference, it must be either too far forward, or too far back, or the feet must be elevated over the wheel, further increasing the challenge of starting up.

These problems can be addressed, at the cost of further complexity, by adding a third wheel. A tricycle presents no balance problem, and no need to remove one's feet from the pedals when stopping. If the pair of wheels is at the front, the feet fit neatly in between, and there is no need to place the wheels to the front or back of them. The result is a totally dif-

ferent riding feel: more like driving a formula race car than riding a bike. The objective of this project was a comfortable longer-distance commuting vehicle. The design emphasizes light weight and low rolling resistance com-

binated with durability and stability in road-holding and braking. Secondary objectives were minimum space requirement on the road and easy portability into and out of buildings. Conflicts between light weight and durability were resolved in favor of durability. The resulting 17.3-kg (38-pound) weight is a

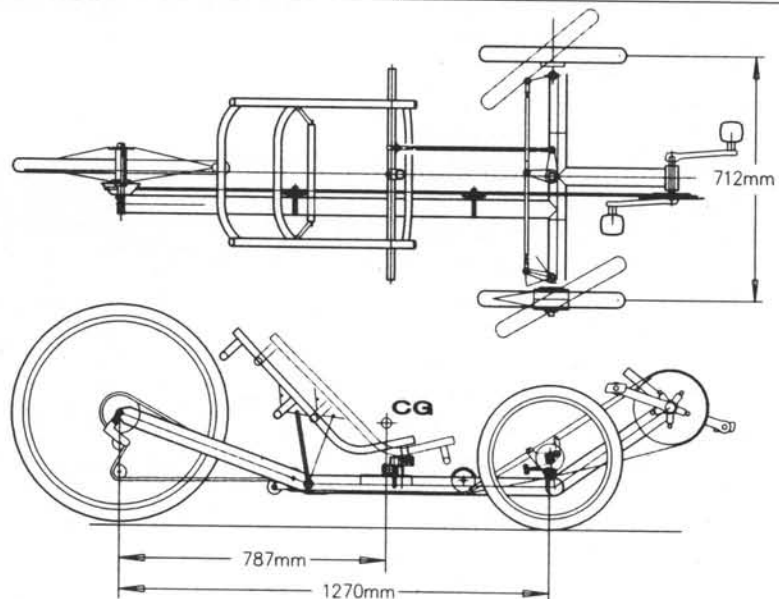

Figure 2 TRYK layout

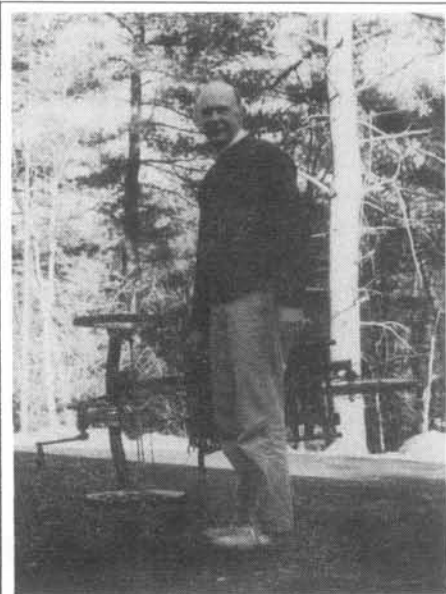

Figure 3 Carrying the TRYK

820 mm with a track of 712 mm. It does, however, fit through my 830-mm front door, and I can carry it without it dragging on the ground (fig. 3). Its width ensures that the 16" (349 ETRTO) front tires do not drag on the rider's leg in turns. My experience so far is that this width causes no practical problem on the road.

Placing the odd wheel in back was primarily the result of subjective preference: I like that look better. But there are some objective advantages: a single drive wheel on centerline provides centered propulsion with a simple chain drive. Paired wheels in front provide space for feet and chainwheel, and can be steered with kingpins and linkage similar to a go-kart. Finally, braking by internal hub brakes in the two front wheels works particularly well.

I determined the wheelbase by positioning the rider behind the front wheels a sufficient distance to avoid braking instability, and then putting the drive wheel as close behind the rider as possible. Two kinds of braking instability need to be avoided. The first is that common to upright bicycles, and also to tricycles in which rider weight is too far forward: tipping forward and, in the case of tricycles, digging the sprocket into the road. This effect is nicely illustrated in the picture on page 3 of reference 4. It can be avoided by ensuring that some weight remains on the back wheel during the hardest (1.0g) stop. A second instability, ground looping, appears to be the

result of unbalanced braking, but in reality is caused by insufficient weight on the back wheel, so that it provides no directional "ruddering" effect. This instability can be prevented by ensuring that 10 or 15 percent of the weight remains on the rear in a hard stop. With a 300-mm CG height, the front wheels are 480 mm in front of the CG. Setting the rear wheel size at 26 inches (to enable use of standard gearing) put the wheelbase at 1.27 m, to accommodate my long legs.

Readers familiar with the front-wheel placement of most production trikes will note that the TRYK's front wheels are farther forward, and the wheelbase longer than usual. In addition to the improvement in braking stability, this brings two benefits and two problems. The first benefit is also one of the problems: a greater percentage (38%) of the vehicle weight rests on the drive wheel. The benefit is traction under marginal conditions. The problem is the greater side load under hard cornering, great enough to cause "potato-chip" buckling of a standard bicycle wheel if used on the rear (covered in detail below). A second problem is that the front axle comes close to the rider's heels. The second benefit of this front-axle placement is that there is no wheel-hand interference, even with underseat flat-handlebar steering.

The seating and steering arrangements are the remaining determinants of the layout. I chose a Ryan (Ryan

Recumbent Cycles, Nashua, NH) mesh seat to provide back ventilation and minimize weight. It is tipped backward to a 45° backrest angle to avoid too great an angle at the hips and to reduce frontal area. Five inches (127 mm) of longitudinal adjustment is provided by sliding the seat clamp along the main tube, with the steering pivot attached, to maintain a constant relationship to the underseat handlebar. This arrangement is comfortable because the hands fall naturally onto the grips. Control is precise and it takes standard shift and brake levers. Getting onto and off of the TRYK is easy because nothing of the steering system protrudes above the plane of the seat. This arrangement does occupy more space under the seat than two alternative arrangements: short vertical bars at either side of the seat pivoting in opposite directions about a transverse axis, as used on the Thebis4, or a single joystick attached by a universal joint to the Pittman arm, as used on the Windcheetah 2.

Brakes

Each front wheel is fitted with a Sachs (Sachs Bicycle Components, Yorba Linda, CA) VT7000 70-mm internal drum brake equipped with sealed cartridge bearings and a CrMo axle. The 12-mm axle diameter makes it possible to use the original axle in a single-sided mount. Figures 4 and 6 show the mounting to the steering kingpin. Torquing up the inboard axle nut places the stack of bearing inner race, steel spacer, backing

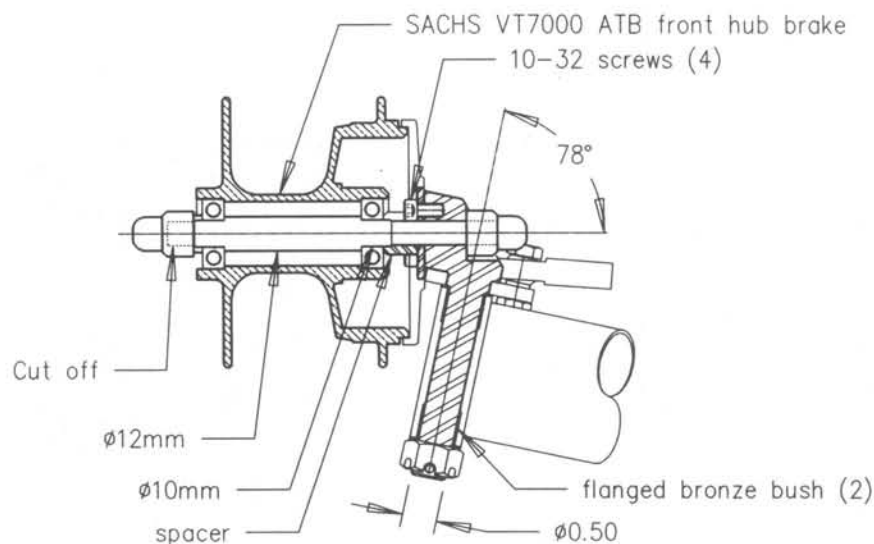

Figure 4 Front hub and kingpin

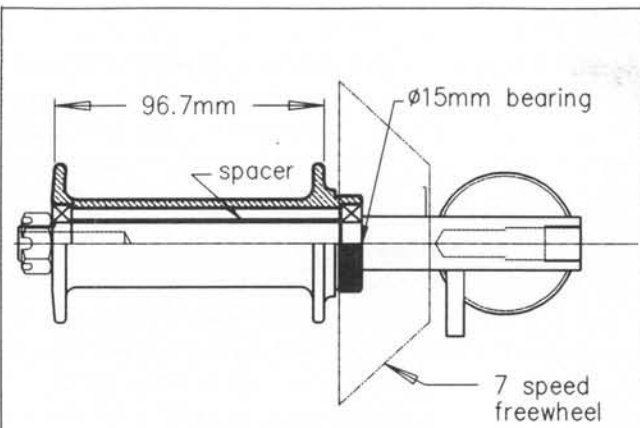

Figure 5 Rear hub

plate and kingpin flange in compression, creating an effective axle diameter of 16 mm by the same effect as that utilized in prestressed concrete. Four 10-32 screws prevent backing-plate rotation. Spoked into the 16" wheels, these brakes provide sufficient braking torque to skid the wheels with moderate hand pressure. Since most (but not all) of the weight transfers to the front wheels on braking, stopping distances are very short. To ensure that the rear wheel doesn't skid, no rear brake is fitted. Each front brake is operated by its own hand lever. This arrangement was installed initially as a time-saving measure, with plans to fit a force-balancing lever at a later date. This turned out to be unnecessary, because the rudder effect of a rolling rear wheel with sufficient weight on it gives stable braking even if only one side is operated. I had hoped to produce sharp turns by using the brakes independently, as in a tracked vehicle, but it's too stable for that.

Frameset

The large-diameter cruciform frame has been adopted in most current tricycle designs because it provides the requisite torsional rigidity with minimum weight, and minimizes welding. Multitube space frames were used in the original Tricanter1 and the Aerocoupe, but have to be heavier to get adequate torsional rigidity, because the need for accommodating the rider prevents complete triangulation of the trusswork. The TRYK frame is 2"x.049 wall (50.8x1.2mm) 4130 aircraft tubing and weighs 4.77 kg (10.5 lb). This gives a torsional rigidity for the main boom of 129 N-m/degree, resulting in a twist of 0.70 degree on an 0.7g left turn and 0.31 degree under

static loading. I used steel rather than aluminum because I wanted to be able to weld it without subsequent heat treatment, for ease of fabrication on a single vehicle. I would have preferred to bend, rather than mitre, the angles in the boom and front axle, but bending thin-wall high-strength steel is not possible without expensive tooling. Aluminum tubing (2" dia. x .120 wall 6061-T6) would solve the bending problem, but require glued joints or post-weld heat treatment. The majority of the joints are TIG welded. I tack-welded the tubes in position without a jig, and took the frame to a professional for the TIG welding. The remainder of the joints are fillet-brazed.

Although I have not measured it, the stiffness of the frame as measured by pedal deflection when the vehicle is held stationary is about right: there is some sense of compliance without a sensation of power-wasting deformation. This stiffness is affected by the chain-idler mountings as well as the frame itself.

Wheels

The front wheels are Weinmann 16x1 3/8 (349 ETRTO) alloy rims spoked into the Sachs hubs with 36 14-gage (2.0mm) stainless spokes, cross 2. The special 142-mm length was made up by the Cycle Loft of Burlington, MA. Although current usage seems to favor 20" front wheels, the smaller ones do have some advantages, especially now that 100-psi (7-bar) tires are available for them (Cyclo-Pedia, Adrian, MI). Braking and resistance to side forces are enhanced because of the smaller radius.

They provide increased clearance for the legs and hands, important when a narrow trackwidth is used. Finally, they facilitate lowering the front axle, to keep it away from the heels when it is located well forward.

The rear wheel presented a special problem. With 41 kg (90 pounds) resting on it, it would encounter side forces probably exceeding 400 N when hard cornering coincided with a bump. I tested a 27" front wheel (36 2-mm spokes, 68-mm flange spacing, symmetrical) for strength against lateral load. It failed at 400 N, buckling in a potato-chip mode. Bicycle rear wheels, moreover, typically have flange spacings of 55 mm. For this reason, I had a special hub made up with 96-mm flange spacing (Phil Wood Co., San Jose, CA). Since the hub would be special, it could be cantilevered from one side, simplifying the frame (see fig. 5). A sturdy mountain-bike rim (Ritchey, 395g) with 36 2-mm spokes provides further insurance against buckling.

Drive Train

In principle, the drive train is quite straightforward: a completely standard 21-speed mountain-bike indexed-derailleur chain drive, except that three normal chains are connected together to provide the requisite length. The chain routing has, however, required the majority of the development effort. Four

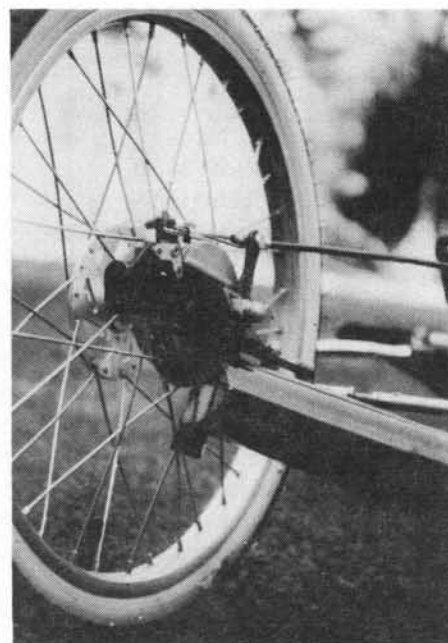

Figure 6 Front-hub mounting, brake and wheel

idlers, machined from nylon #40 industrial sprockets (Stock Drive Products, New Hyde Park, NY) divert the chain under the seat-adjusting clamp. Clearance is so limited there that the chains must run side-by-side. It should have been no surprise that chains under tension want to be as straight as possible: they don't like being diverted, and thus (particularly when going over bumps) find ingenious ways to get free of their idlers. Keeping them in their place has required large teeth on the idler sprockets, and auxiliary idlers (non-load-bearing) made from derailleur jockey pulleys.

Clipless pedals are an invaluable aid in keeping the feet on recumbent pedals. In the TRYK, there's no need to detach at stops, and so they become very convenient.

Steering

The steering geometry is conventional Ackerman (wherein the steering-arm joints lie on a line between the kingpin and the center of the rear axle). This provides for the inside wheel following a tighter radius in turns than the outer. Camber is 0°, and kingpin inclination 12° giving a scrub radius of 18.6mm (0.73 inch). Caster is 10°, giving a caster trail of 38.6 mm (1.52 in.). The 12.7-mm kingpins (an inverted LeMoine design, see fig. 4) are machined in unit with the axle mount from 1020 steel, and the steering arms TIG-welded on, taking care not to overheat the steel in the highly stressed junction area. A centrally pivoted bell crank relays the motion of the longitudinal drag link (which is adjusted for length when the seat is moved) to the lateral tie rods through aircraft ball-rod ends. At the handlebar end, the attachment is movable to adjust the steering ratio. A ratio close to unity seems about right.

Performance

My expectation that reduced frontal area would lead to an improvement in all-around performance (compared to an upright bicycle) has not been met. The TRYK is better aerodynamically, but its weight of 17.3kg and the recumbent position slow it on hills. On a free-rolling test down a local hill, the TRYK would reach 16.3 m/s (58.7 km/h,

36.5mph), where a road-racing upright bicycle reached 14.3 m/s. However, going uphill, the TRYK fell behind, 3.1 m/s to 4.9 m/s. On a 30-km (18.5-mile) commute, the hill effect, and, probably, the rolling-resistance penalty of the extra wheel mentioned by Whitt and Wilson³ combine to increase its trip time from 1 h even to 1 h 10 m. Since traffic and wind conditions vary from day to day, the commute-time comparison may have a five-minute error, but these numbers represent the best of perhaps eight trips on each vehicle. For my particular commute, the TRYK's increased comfort just about balances the upright's increased speed, and I've found I enjoy alternating between one and the other to keep the trip enjoyable.

Visibility on the road is an issue with low recumbent vehicles of this type. To increase it, I use a flag, inserted in the left seatback tube. I commute in heavy suburban traffic. In 1500 km of riding, I have had no close calls, and thus no visibility problem that I can report, although there are drivers who think I shouldn't be sharing their road space, and let me know in a limited variety of unprintable ways! Fortunately, for each one of them, there are a fair number of others giving a delighted thumbs up.

As mentioned previously, tip-over stability is less than absolute. I have tipped over on two occasions, each time without injury, as the distance to the ground is short. Leaning into corners is good insurance in negotiating fast, sharp corners, but might not be done in an emergency maneuver, so there is some reason to be careful.

A fairing has not been planned, because its effect of improving speed downhill at the expense of extra weight going up does not seem an advantage in my usage pattern. Suspension was not included for much the same reason: the mesh seat and resilient frame boom take some of the shock out of bumps, and ride improvement at the cost of extra weight would be undesirable.

Conclusion

The project's general goals of comfort, stability, utility and durability have been met. I believe, all things considered, the TRYK is safer than a bicycle, but this is a very subjective judgment. It

is certainly much more comfortable. The cost of construction, about \$1400 not including some machining I had done professionally to save time, has been worth it, just for the feeling of speeding down the bike trail in a miniature formula car!

References

1. Raine, J.K. and Amor, M.R., (1991) MODELING ENERGY CONSUMPTION ON THE TRICANTER HPV, Human Power vol. 9/3 & 9/4 pp.26-33.
2. Ballantine, R. and Grant, R. (1992) RICHARDS' ULTIMATE BICYCLE BOOK. New York: Dorling Kindersley. pp 128-131, an excellent photo of Mike Burrows' Windcheetah.
3. Whitt, F.R. and Wilson, D.G. (1982) BICYCLING SCIENCE. Cambridge: MIT Press. p.171.
4. (1993) THE TRICE RECUMBENT TRIKE, Recumbent Cyclist News #16. p.3.
5. (1992) THE THEBIS 201 TOURING TRIKE, Recumbent Cyclist News #10, p.1.

Allen Armstrong, 34 Robinson Road,
Lexington, MA 02173, USA
Phone: (617-861-0029)
e-mail: alarmstro@aol.com.

Allen Armstrong is a mechanical engineer who designs focused-ion-beam semiconductor-manufacturing equipment. He invented the Positech indexing derailleur and, with David Gordon Wilson, the Positech wet-weather caliper brake.

Systems design of the Dragonfly: a human-powered helicopter

by
Andrew Cary, Tim Morthland and Eric Loth

Abstract

A human-powered helicopter was designed using non-linear-optimization techniques based on an objective function determined by a coupled aerodynamic-structural discretized analysis. The structural analysis predicted local stresses and rotor deflection, which were iteratively used to determine the radial ground-effect distribution and the total aerodynamic forces. This systems-engineering design procedure allowed a cohesive methodology that permitted detailed and automated tradeoff decisions. The best overall configuration was determined to be a combination of two different blade pairs on a single shaft with tip propellers on one of the blade pairs in order to achieve a stable and power-efficient design. All essential structural and aerodynamic design parameters of the configuration were simultaneously introduced as either variables or bounded constraints for the non-linear gradient-based optimizer which minimized the power required for a 68-kg pilot to hover at a craft altitude of two meters. The performance calculation of the optimized design predicts that only 680-watts are required to hover at this condition.

Introduction

The motivation for the present study is the Igor Sikorsky prize, established in 1980 by the American Helicopter Society, which will be awarded to the first human-powered helicopter (HPH) that reaches a height of 3 meters during a one-minute hover flight. Human-powered-helicopter designs have borrowed extensively from their fixed-wing counterparts, and while approximately 17 HPHs have been constructed internationally, only two have achieved documented flight: the California Polytechnic State University--San Luis Obispo's (Cal Poly) Da Vinci III in 1989 and, more recently, Naito's Yuri I in 1993. Each of these craft, after nearly a

decade of development, hovered at an altitude of about 0.2 meters for a few seconds. The Da Vinci III employed a unique rotor-tip propeller propulsion system which eliminated the need for a counter-torque device (ref. 1). A stationary chassis was suspended by bearings from the two rotor blades, which rotated due to the aerodynamic force created by propellers at the rotor tips. While a small degree of chassis rotation, on the order of one RPM, is inevitable due to bearing friction, the result is an efficient and light-weight drive system. The flight video indicated several instabilities, with the most notable being an uncontrolled rolling motion.

This was the reason for the flight termination (after eight seconds), as opposed to the expiration of pilot power or to structural failure. Therefore, stability and control are also important aspects of a successful HPH design.

The Yuri I was a radically different concept developed by Akiro Naito of Japan that employs four separate rotors, each located at a 10-meter radius from the pilot and chassis at 90-degree intervals. The successful flight attempt in the fall of 1993 led to a 5.5-second hover.

Previous HPH research include Naito's Papillon designs (ref. 2) and Cranfield's Vertigo design (ref. 3). The Vertigo project in England employed counter-rotating blades and was primarily unsuccessful due to the dynamics of the rotor-blade combination. The flow over the lower rotor blade separated

during rotor crossover, leading to blade fatigue and craft instability.

The design of the UIUC project, the X-391 Dragonfly, was started in 1990 and employed the following basic methodology: 1) determine the best overall concept, 2) develop subsystem analysis methods, 3) optimize the entire design using systems engineering with non-linear gradient-based methods, and 4) perform small design changes to minimize construction complications. Each of these phases is summarized in this paper, with reference to construction techniques only as they affect the design process.

Systems engineering combines several engineering disciplines in the design process to create a product that satisfies

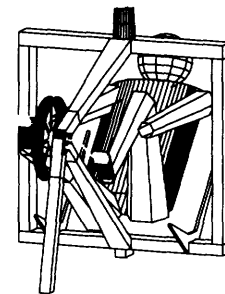

(a) Chassis and pilot orientation

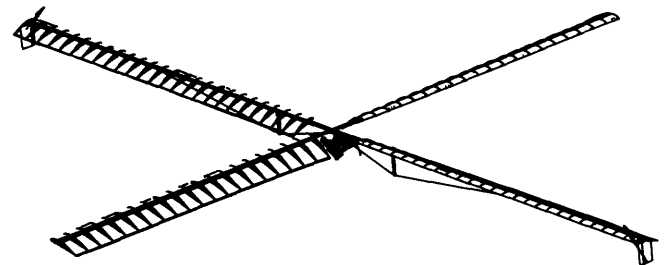

(b) Complete design

Figure 1 X-391 Dragonfly schematics

all of the requirements while optimizing a set of parameters. In the aerospace industry, these disciplines can include structures, aerodynamics, dynamics, propulsion, and manufacturing and represent a wide variety of constraints and analyses. By combining these into a single analytic description of the craft performance, as was done in this study, a more effective optimization of the design may be achieved. This technology is often referred to as Multi-Disciplinary Optimization. Rohl and Schrage (ref. 4)

categorize multilevel decomposition techniques as sequential (evaluate through further refinements), parallel (evaluate subsystems simultaneously), and hybrid. The latter approach is used herein, with a preliminary design analysis being used to establish the best overall configuration and initial parameter estimates, followed by a level of parallel inter-related subsystem analyses to finalize the theoretical optimization. For the parallel optimization of the present study, the aerodynamics and structures were integrated for a simultaneous subsystem optimization, while the dynamics, propulsion, and fabrication issues were incorporated through empirical models and system constraints.

Configuration identification

In order to optimize the craft design, the general configuration must first be selected. This selection itself involved a crude optimization of several candidate designs by estimating likely craft weights and propulsive efficiencies. Since estimates of the rotor diameter yielded values as large as 30 meters for a single pilot, it was assumed that the increased size dictated by employing multiple pilots, as well as the complexity of assuring a uniform distribution of power production, made a two-person crew impractical. To preserve static stability, it was also assumed that the pilot, who will constitute the majority of the mass, would be under the rotor disk plane.

Several ideas for basic configurations that resolved the anti-torque requirements imposed by the use of a rotor system were considered, of which only five concepts seemed likely: a conventional tail-rotor design; a tip-propeller driven rotor design, e.g. Da Vinci III; two concentric counter-rotating rotors, e.g. Vertigo; two or more counter-rotating rotors displaced from each other, e.g. Yuri I; and a duct-based ground-effect machine using either counter-rotating propellers or a multiple duct system. Each of these candidate concepts was then designed based on an average flight altitude of 1.5 meters to allow a direct comparison of the power required to hover. This included estimation of such items as

component weights, ground effect, propeller efficiency, and properties of advanced materials, as well as the use of rotor-disk theory and a cantilever-beam model (ref. 5).

The weight of the long rigid spar(s) necessary for the tail-rotor design or the displaced counter-rotating design was found to render these designs inferior due to the insufficient compensation in propulsive efficiency. For the conventional rotor, an additional disadvantage is the diversion of more than 5% of the human power for the non-lifting tail rotor. These additional spars are not necessary on the tip-driven design. The concentric-shaft counter-rotating idea was eliminated due to power losses associated with rotor overlap and due to concerns of dynamic interference similar to those experienced by the Vertigo project. The most reasonable of the duct-based ground-effect machines in terms of stability and efficiency is a quadruple-duct peripheral-jet design (ref. 6). While theoretical thrust augmentations for ground-effect machines can be significant at low altitudes, power losses of the fan and ducting yield an overall poor efficiency. Therefore, based on quantitative evaluation of the above configurations, the tip-driven design was found to be superior to the extent that further optimization was limited to this one design. This superiority was due to the minimal increase

in mass associated with resolution of the counter-torque problem, potentially high efficiency of the rotor, overall simplicity, and proven success. Efficiency comparisons by Naito (ref. 2) support this conclusion. A craft with a 15-m rotor radius was estimated to weigh 117 kg with pilot and to require only 470 watts to hover at 1.5 m.

It is believed that the dynamic instability of the Da Vinci III stemmed

from the small moment of inertia about the spar axis that allowed an unbalanced overturning moment to produce a significant angular acceleration. Additionally, due to the angular momentum of the large rotors, precession can lead to dynamic stability difficulties if there is an unbalanced moment on the craft. To counter these stability problems, a second set of rotor blades was added with the size of this pair determined by a balance between power and dynamic concerns. This compromise resulted in a large-radius blade pair (LRBP) and a short-radius blade pair (SRBP).

Optimization methodology

Because of the need to design a near-optimal craft (i.e. maximum altitude for a power of about 600 W), it was believed that a systems-engineering approach would result in a craft superior to one in which individual subsystems were independently optimized. For instance, spar mass and deflection have strong influences on the aerodynamic design of a rotor blade which is then reflected in the structural loading. By iterating between a code which analyzed the rotor structurally and one that analyzed it aerodynamically, a prediction could be made of the power required for a given helicopter design to maintain a specified altitude. Using estimated efficiencies for the transmission system (η_{trans}) and the

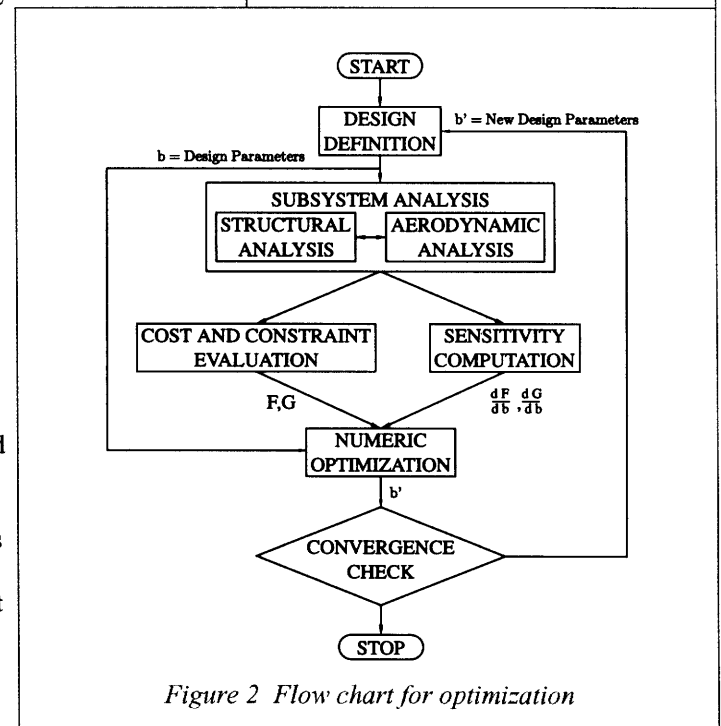

Figure 2 Flow chart for optimization

propellers (η_{prop}), the power required from the pilot could then be determined,

$$P_{pilot} = \frac{P_{rotor-req.}}{\eta_{prop}\eta_{trans}}$$

This pilot power provided the design with an objective function to compare different variations of the design. An alternative approach would be to consider a fixed pilot output and seek the maximum altitude that a given design could achieve, but such a search is more costly. A brief description of the models simultaneously used for the optimization is given below, where important details are given in Ref. 5.

Spar structural model

Carbon-fiber tubular spars with Mylar-covered airfoil-shaped foam ribs are used for the rotor blades. Varying thicknesses and orientations of unidirectional carbon-fiber pre-preg are laid over an aluminum mandrel of constant outer diameter. These carbon tubes are cured, removed from the mandrel, and joined together to form the spars. The structural model was based on this construction and assumed that the foam and Mylar would not influence rotor deflection. Guy wires were used to add further stiffness to the LRBP with a minimal weight penalty. Using Euler-Bernoulli beam theory and the moment distribution along the rotor span obtained from the aerodynamic analysis, the rotor deflection was determined. The Young's modulus and moment of inertia about the z axis are functions of the rotor radius due to variations in carbon-fiber orientation, spar thickness, and spar-segment radius.

Modes of failure for bending stress, shear stress, and buckling were considered in the structural analysis. The bending stress, σ_r , was based on a symmetric beam. The shear-stress distribution was obtained by dividing the shear flow of a homogeneous beam by the local thickness of the cylindrical beam. The onset of buckling was computed from a relation given by Bruhn (ref. 7). The required stresses were required to satisfy the critical relation

$$\left(\frac{\sigma_r}{\sigma_r^{max}}\right)^2 + \left(\frac{\sigma_b}{\sigma_b^{max}}\right)^2 \leq 1.0 \quad (1.0)$$

for combined shear and bending, where σ_r^{max} is the maximum allowable bending stress, σ_b is the buckling stress, and σ_b^{max} is the maximum allowable buckling stress.

In addition to providing a viable spar design, this analysis yields rotor deflection and spar weights that are required by the aerodynamic analysis.

Rotor aerodynamic model

The primary aerodynamic model determined the thrust required for the craft by summing the component weights and applying an acceleration factor reflecting the craft's vertical acceleration. Using the thrust and an analytically determined blade lift coefficient, the rotor angular velocity could be determined. Since the blade lift coefficient involved terms containing the rotor angular velocity, it was necessary to solve the system iteratively. The resulting solution contained information used to determine the local loading of the spar and the power required to maintain the specified flight condition, which were required by the other subsystem models.

The blade lift coefficient was determined from the planform and the angle-of-attack distribution. This resulted in fewer iterations than specifying the pitch distribution and provided more direct control in shaping the aerodynamic characteristics of the rotor. The pitch could later be determined from the induced-velocity distribution. The induced velocity was represented as the superposition of three factors: local loading, propeller wash, and ground effect. The local loading contribution was determined from the modified blade-element theory by equating the thrust at a local element to that predicted by the actuator-disk theory (refs. 8,9). The propeller wash was modeled as having solid-body rotation at the same angular velocity as the propeller inside the propeller's radius and a matched irrotational flow exterior to it (ref. 10). The ground-effect model chosen consisted of a series of vortex rings: it was validated with data for ultra-low rotor altitude (ref. 5).

The spar deflection obtained from the structural model also plays a key role in the ground-effect calculation since the upwash is a function of the lifting

element's local altitude. Additionally, it causes the local blade element to rotate out of the rotor plane, changing the direction of the lift vector slightly, which was accounted for in the analysis.

This analysis could then be performed for a given mass and planform distribution. Finally, the power required to maintain the specified flight condition was determined by integrating the parasitic and induced-drag moment over all of the blades and adding the power required to climb. The climb-power term indicates that the best flight profile may not be to hover in high ground effect for as long as possible and to then "pop" up toward the 3-meter goal, as this would result in not only a large climb power, but also a reduction in the effective angle of attack due to the increased downwash.

Because the X-391 Dragonfly's rotor operates in the low-Reynolds-number regime, it was desired to find a rotor airfoil that was designed for a high lift-to-drag ratio in this range and that was also tolerant to minor construction errors. These requirements led to the selection of the DAE class of airfoils designed for the Daedalus project by Mark Drela (ref. 11). The performance of these airfoils was included in the rotor analysis through the use of a Reynolds-number-dependent model.

Propeller analysis

The propeller analysis was largely decoupled from the rotor analysis; however, strong links were maintained in determining the free-stream velocity seen by the propeller and in the strength of the propwash, as well as the propeller efficiency. In order to obtain a propeller with the greatest efficiency, a minimum-induced-velocity design (ref. 12) was chosen. Surveying several candidate propeller airfoils led to the surprising choice of a NACA 0012 airfoil operating at an angle of attack corresponding to the maximum L/D ratio. This airfoil proved superior due to the construction constraint of a 20-mm root chord and a desire for maximum efficiency. These small chords are a result of distributing human power to two propellers, instead of only the one used in most HPAs. The final design had a radius of 0.82 meters and a design efficiency of 0.87 at 400 RPM and a shaft power of 300 W.

Power-plant model

An empirical model of the power that could be provided to the propellers and an accurate estimate of the mass associated with such a power source were required for input to the optimizer. For a one-minute period, cycling was found to yield more power than rowing or combined cycling and hand cranking (ref. 13). To evaluate prospective pilots, a pilot cost function, K , was formulated based on initial estimates of craft weight, pilot mass, and the ideal power-thrust relationship:

$$K \equiv \frac{(m_{pilot} + m_{craft})^{3/2}}{P_{pilot}} \quad (2)$$

Based on several athlete's K values, a member of the U.S. National Cycling Team was selected as a pilot model for the optimizer with a projected mass of 68.2 kg and an output of 680 watts.

The power-plant model also includes the chassis and transmission in terms of both mass and efficiency of delivering power to the tip propellers. A string pull-down transmission system as used in the Da Vinci III design was selected since it was deemed to be the lightest and most efficient drive system. This system was based on Kevlar™ string which was wrapped around propeller spools, funneled through Teflon O-rings in the spar to the chassis, and finally taken up by the pedal crankshaft and had a total mass of 1.2 kg and an estimated 94% efficiency. The geometries of the pull-down and take-up spools were selected such that a constant pedal rotational speed would result in minimum off-design performance degradation of the propeller efficiency caused by variations in rotor speed and effective spool diameter.

To optimize pilot performance while keeping the rotor plane as low as possible, a recumbent position with a mean hip angle of 75 degrees (refs. 14,15) was adopted for the chassis depicted in figure 1a. The chassis was designed for minimum overall mass while supporting the pilot's gravitational and dynamic forces based on a multi-member finite-element model. This results in a total chassis, pilot and transmission mass (everything except the rotor itself) of

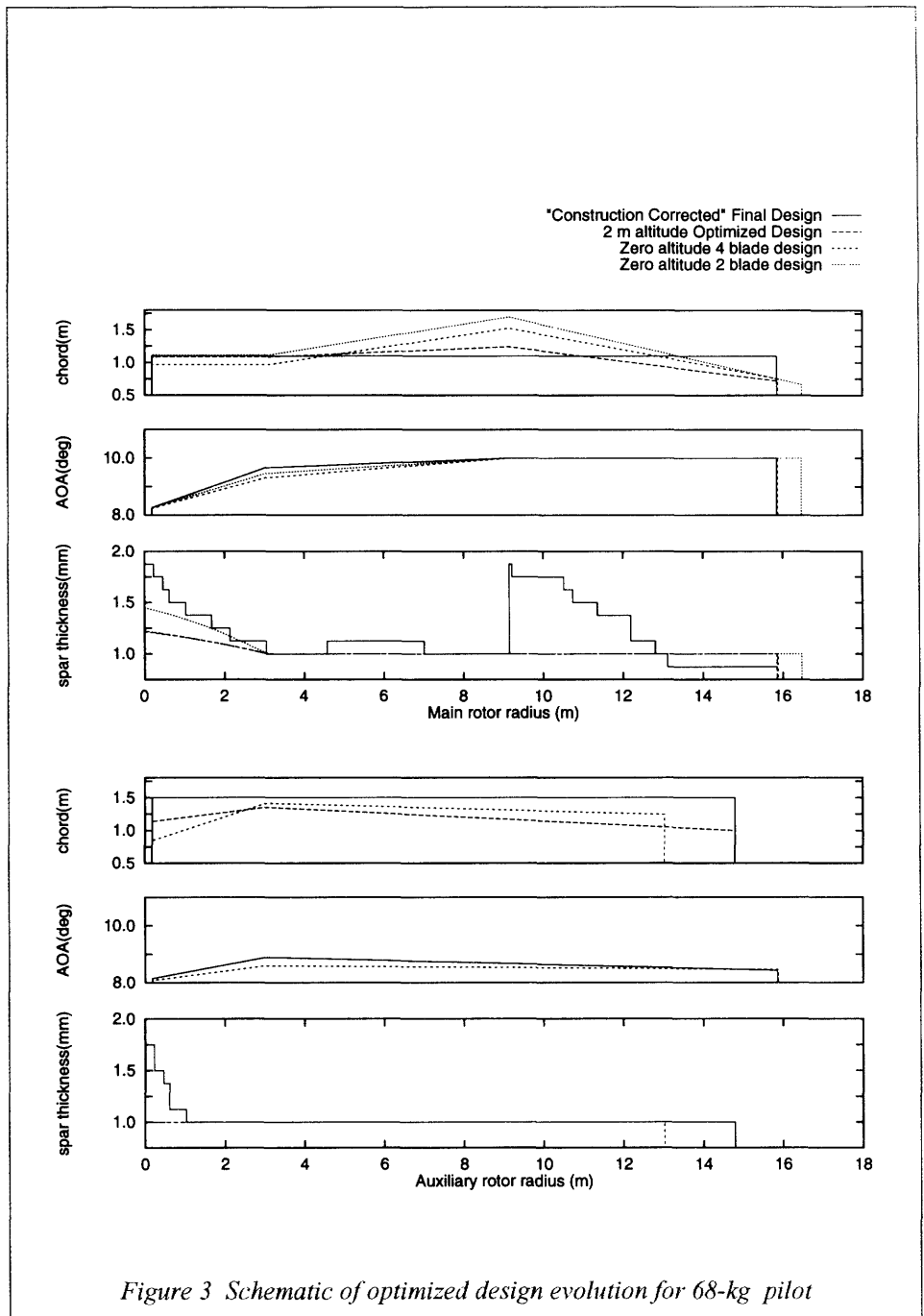

Figure 3 Schematic of optimized design evolution for 68-kg pilot

73.2 kg with a net power delivered to the propellers of 640 watts.

Optimizer program

The optimal design was determined through the use of a program that minimizes an objective function, G , subject to a constraint vector, F , through modification of the vector of design variables, b . This program uses derivative information relating the design variables to the constraints and objective function to modify the design variables strategically until an optimal solution is obtained and all constraints are satisfied. The design

optimization process is depicted in figure 2.

Since both the objective and the constraints are nonlinear functions of the design, the method of sequential quadratic programming (Vanderplaats, ref. 16) was selected because it is well suited for this class of problems. The optimization can be generally expressed as a nonlinear constrained minimization problem,

$$\begin{aligned} &\text{minimize } G(\mathbf{b}) \\ &\text{subject to } \mathbf{L} \leq \left\{ \begin{array}{c} \mathbf{F}(\mathbf{b}) \\ \mathbf{b} \end{array} \right\} \leq \mathbf{U} \quad (3) \end{aligned}$$

where L and U correspond to the lower and upper bound on either the constraint vector $F(b)$ or the design vector b . The optimizer modifies the design variables by finding a search direction in the design space which does not violate the constraints and rapidly minimizes the objective function. Subsequent search directions are chosen based on gradient information and the objective is sampled along each of these search directions until an optimal solution is found.

Optimized solution

Design variables and constraint definition

With the aerodynamic and structural programs developed to analyze a particular configuration, the optimization could be performed once a design space of variables and constraints was defined. Because the computational time required for the optimization increased rapidly with the number of variables and constraints, only key parameters were considered (ref. 5). Limitations imposed by construction techniques dictated some of these constraints. For example, the carbon-fiber-epoxy spars dictated a constant inner diameter, a minimum thickness of 1 mm, and a maximum length of 7.2 m for any spar segment.

The spars were divided into several construction-size sections, each of which had several structural parameters. The diameter of the mandrel, spar length, and coefficients representing a quadratic composite thickness were introduced as variables for each segment. Further, each spar segment's planform and angle of attack distribution were assumed to have a linear variation. While a greater degree of freedom for these parameters would be desirable, it would both require additional design variables and be more difficult to build. This discretization resulted in 41 variables which were normalized to be of order unity.

Although construction limits for each of the variables were introduced, additional constraints had to be imposed based on the discretization of the design space and the particular design evaluation. In the first category, the outer spar diameter was required to be less than the thickness of the airfoil section with

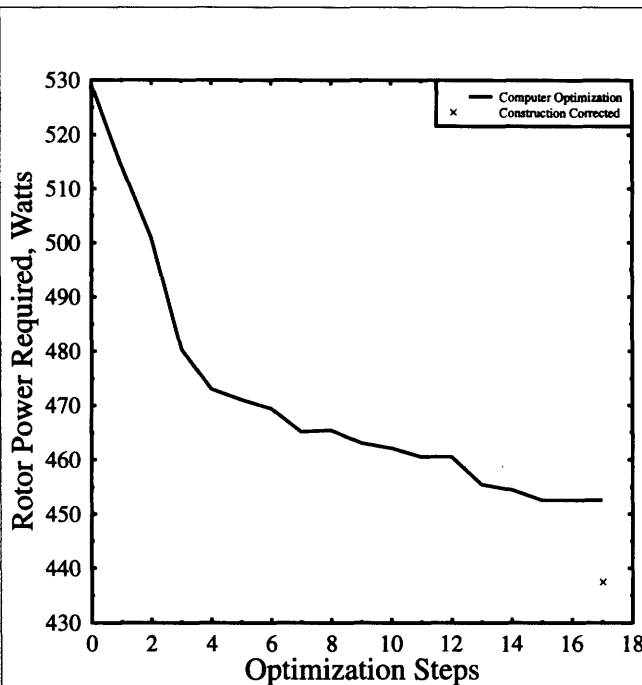

Figure 4 Convergence history for 68.0-kg pilot at one-meter altitude

sufficient clearance for construction.

The second category included limitations on deflection corresponding to a steady-state coning angle of 10 degrees to maintain the Euler-Bernoulli assumption and the small-angle assumptions used in the models. The bending and shear stresses were sampled at six locations per blade to prevent designs that were structurally unsound. Finally, in an effort to incorporate as much inherent stability into the design as possible, the ratio of the flapping moments of inertia of the SRBP to the LRBP was required to be greater than 0.5. These limitations resulted in ten linear constraints and 47 nonlinear constraints. Details of these constraints and the following results are given in ref. 5.

Results: discussion of optimization

Since preliminary results indicated that an optimized design should not have extreme difficulty hovering in high ground effect, the design point was set at a craft "cruise" altitude of 2.0 m. This design was individually optimized for pilots weighing 60.0 kg, 61.3 kg, and 68.2 kg and the results compared for the impact of weight variation on the design. Each of these optimizer runs required approximately 700 CPU minutes on a CONVEX C240. The resulting variations in the design were, for the most part, small with the only significant

difference among the three optimized designs being the radius of the SRBP, which increased monotonically with pilot mass from 13.5 m (60.0 kg pilot) to 14.2 m (61.3 kg pilot) to 14.8 m (68.2 kg pilot). Among the three designs, the LRBP maintained a nearly constant radius of 16.8 m and had a chord distribution that was essentially constant on the inboard section, increased over the middle section, and had a fairly strong taper to end up with an average tip-to-root ratio of 0.6. As the radial station is increased, the angle of attack profile quickly approached the maximum-lift-to-drag-

ratio angle. The composite-thickness profiles showed a tendency toward the 1-mm constraint, but the spar cross-section was larger at this altitude than at a zero craft altitude, making the rotor more stiff. Note that the maximum predicted coning angle was less than 10 degrees and hence the imposed constraint did not limit the design. Four designs, ranging from the initial two-bladed design to the final "construction corrected" design are compared in figure 3. A convergence history for the optimization process of the power required to hover for a 60 kg pilot at a craft altitude of 1 m is given in figure 4. The craft weight varied from 40.14 kg to 44.14 kg while the "cruise" power varied from 503 W to 570 W as the pilot mass increased.

While these three designs may be optimal with the given constraints, they are not optimal with respect to construction simplicity. Based on the above results, the rotors were subdivided into five segments each and assigned inner diameters that were commercially available and approximately the size determined by the optimization process. The aerodynamics were then compared for 24 planforms for the lightest and the heaviest pilots at altitudes of 1.0 m, 2.0 m, and 3.0 m to survey the power variations stemming from non-optimal chord distributions. This

study indicated that there was only a slight power increase for a constant-chord design that is easier to build. Additionally, some of these configurations led to a smaller required power than the optimized design, but were subject to structural failure. By reinforcing the spars in the vicinity of failure, the modified designs were still viable. Further experiments indicated that a constant LRBP chord of 1.1 m and a constant SRBP chord of 1.5 m provided only a small increase (3.5%) in power over the lowest-power design for the heaviest pilot and had a higher moment of inertia ratio of 0.73. Following manual tailoring of the spar to prevent failure, the predicted power for this design was 606 W for the 60.0 kg pilot and 681 W for the 68.2 kg pilot at cruise conditions. These power figures are significantly larger than those given earlier because they include the losses which will occur between the pilot and the rotor. This design is illustrated in figure 1b.

Many of the characteristics of the design could be qualitatively anticipated, and hence they provided a check for the procedure. For instance, as expected, the angle-of-attack distribution was very close to the optimum (maximum) lift-to-drag ratio of the airfoil. Additionally, increasing the cross-sectional radius of the spar at constant thickness is more effective at increasing both the stiffness and the specific stiffness of the spar than increasing the thickness alone by the same amount. This property was reflected in the optimization that resulted in both the maximum possible spar radius (limited by the airfoil chord) and minimum composite thickness everywhere but near the root of the rotor, where the bending moments are large and a correspondingly larger stiffness is required to prevent failure. Smaller variations in the optimized chord with increased altitude also indicated the expected behavior of a reduction in planform dependency on ground effect.

On the other hand, aspects of the planform design were not as obvious. In general, the optimized results tended to have the smallest possible chord (without constraint violations) over the inner section to minimize drag losses without significant gains in lift. The

chord then increased over the middle section, presumably to take advantage of the higher dynamic pressure for lift production. However, the increased induced velocities at the outer section led to tapering the chord to reduce the induced losses by locally decreasing the lift. The balance among stability considerations, aerodynamic effects, and structural limitations could not have been deduced without a systems-engineering approach to optimization.

Conclusions

A human-powered helicopter was designed with a systems-engineering approach using non-linear optimization techniques based on an objective function determined by a coupled aerodynamic-structural analysis. From several possible configurations, a single-rotor four-bladed design with tip propellers was chosen as the optimum concept. The dimensions of the aerodynamic and structural components were optimized using a systems integrated non-linear gradient-based optimizer. Important features of the optimization included spar material properties and geometry, guy-wire location, the pilot Figure of Merit, and both rotor radii. Post processing, with minor modifications, of this optimum design to one that allowed significantly reduced construction complexity yielded a slight increase in overall performance due to a relaxation of constraints. The resulting 38-kg design, which is under construction, has a 16.8-meter LRBP radius with two 1.63-meter-diameter tip propellers, and a 13.25 meter SRBP without propellers. The performance of the optimized design predicts that a 68-kg pilot would need only 680 watts to hover at a craft altitude of 2.0 meters.

Acknowledgments

Any task such as this helicopter requires the assistance of a large number of individuals, and while it would be nearly impossible to list all who have contributed significantly to this project, it would be remiss if a few individuals were not mentioned. The untiring efforts of Eric Buus, Hagen Dost, Greg Pluta, Mike Showerman, Marcus Veile, Dan Schein, Gabe Rogers, Farooq Saeed, and Tony Wang helped to keep the program

continuing through even the roughest of times. These students surrendered their time, knowledge, and class work in pursuit of a dream. Additionally, the University of Illinois Aeronautical Engineering Department and College of Engineering has supported this project from its conception, along with International Paper and Arthur Andersen. Numerous material donations were made by DuPont, Hexcel, the Flight Research Institute, and Magic Motorcycle.

References

1. Larwood, S. and Saiki, N., "Aerodynamic design of the Cal Poly Da Vinci human-powered helicopter," American Helicopter Society Vertical Lift Design Conference, B-90-WE-24-1000, San Francisco, CA, January, 1990.
2. Naito, A., "Review of developments in human-powered helicopters," Human Power, vol. 9, pp. 1-9, Summer 1991.
3. Cranfield, A. D., "Pedalling towards a vertical take-off," Chartered Mechanical Engineer, vol. 34, pp. 58-60, September 1987.
4. Rohl, P. and Schrage, D., "Preliminary wing design of a high speed civil transport aircraft by multilevel decomposition techniques.," Proceedings of the 4th AIAA/USAF/NASA/OAI Symposium on Multidisciplinary Analysis and Optimization, pp. 244-250, 1992.
5. Cary, A., Morthland, T., and Loth, E., "Systems design optimization of a human-powered helicopter," AAE Technical Report 94-05, UILU ENG 94-0505, 1994.
6. McCormick, B., Aerodynamics of /STOL Flight. Orlando, FL: Academic Press, 1967.
7. Bruhn, E., Analysis and Design of Airplane Structures. Cincinnati, Ohio: Tri-State Offset Company, 1949.
8. Seddon, Basic Helicopter Aerodynamics. AIAA Educational Series, 1990.
9. Nikolsky, A., Helicopter Analysis. New York: John Wiley and Sons, 1951.
10. Loth, J. and Loth, F., "Induced drag reduction with wing mounted propellers," tech. rep., AIAA-84-2149, 1984.
11. Drela, M., "Low-Reynolds-number airfoil design for the M.I.T. Daedalus prototype: A case study," Journal of Aircraft, vol. 25, no. 8, pp. 724-732, 1988.
12. Larrabee, E. E., "Design of propellers for motorsoarers," NASA

Conference Publication 2085, March, 1979.

13. Burke, J., "The Gossamer Condor and Albatross: A case study in aircraft design," AIAA Professional Study Series, AV-R-80/540, 1980.

14. Too, D., "Effect of hip position in cycling," International Journal of Sport Biomechanics, vol. 7, pp. 359-370, 1990.

15. Too, D., "Biomechanics of cycling and factors affecting performances," Sports Medicine, vol. 10, pp. 286-302, 1991.

16. Vanderplaats, G., Numerical Optimization Techniques for Engineering Design: With Applications. New York: McGraw-Hill, 1984.

CAPTIONS

- a.. Rotor loading.
- b. Rotor pitch.

Figure 1: Aerodynamic characteristics vs. radius for final design.

- a. Chassis and pilot orientation.
- b. Complete design.

Figure 2: X-391 Dragonfly schematics.

Figure 3: Flow chart for optimization.

Figure 4: Schematic of optimized design evolution for 68 kg pilot.

Figure 5: Convergence history for 68.0 kg pilot at 1 m altitude.

Andrew Cary is working on his Ph.D. in computational fluid dynamics at the University of Michigan in aerospace engineering, and serves as a consultant to the student group working on the HPH. Tim Morthland is working toward his PhD in Mechanical and Industrial Engineering at UIUC looking at shape optimization. Eric Loth is an assistant professor in aeronautical and astronautical engineering and is primarily interested in experimental and computational unsteady fluid dynamics.

The Dragonfly project has recently restarted after a one-and-a-half year hiatus and it is expected to take a couple of years to finalize construction.

Eric Loth

306 Talbot Laboratory, 104 S. Wright St. University of Illinois, Urbana-Champaign, Urbana, IL 61801
Phone: (217) 244-5581

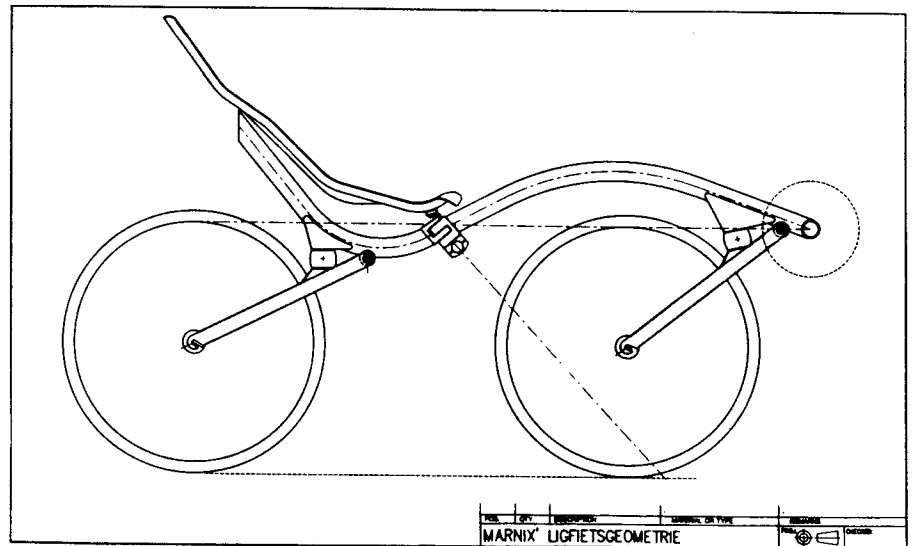
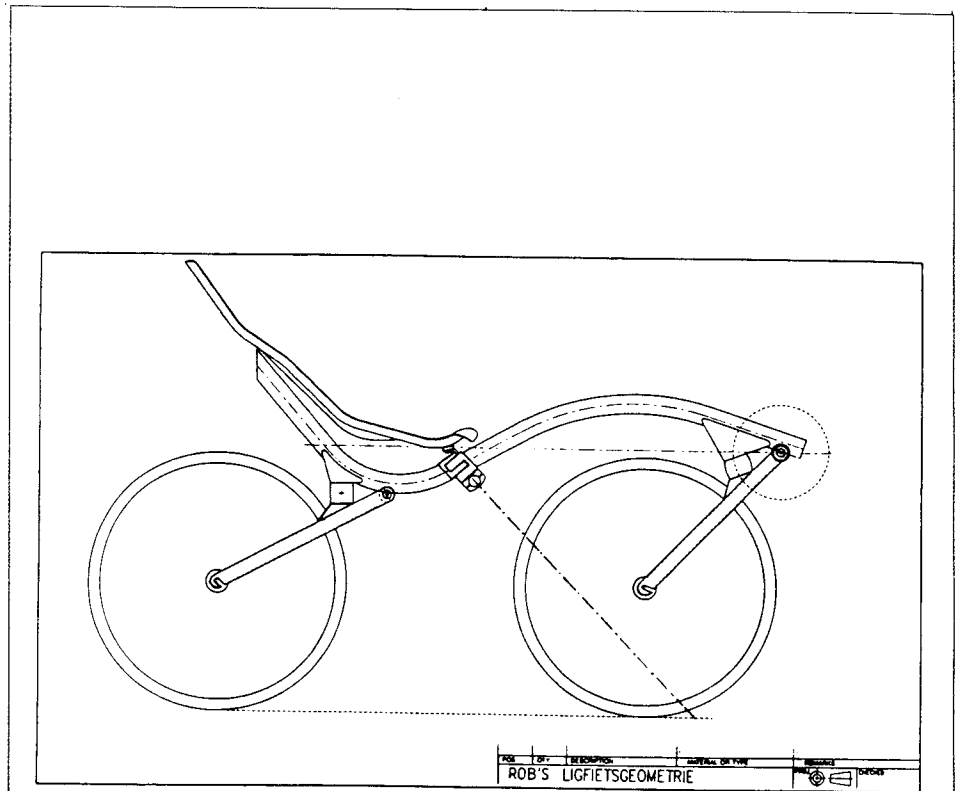

Two versions of Swing Cycle Delft with slightly varying configurations, as drawn by Rob Hofman and Marnix Bakker and reproduced in hpv nieuws 9/6, December 1983. There is suspension on both wheels. The front wheel is driven, and steering is at mid-frame point, as popularized on the Flevo recumbents.

Octogenarian cyclist by W. R. E. "Ron" Beams

(Editorial note: Ron Beams is mentioned frequently in the pages of publications of the Veteran-Cycle Club as an enthusiast for recumbents. He is also not shy about his age. I asked him if he would write something about himself and about his vehicles. This first piece is autobiographical. Dave Wilson).

The editor has asked me, an 88-year-old Englishman, to write about my cycling experiences as an octogenarian. Folk, cyclists or not, seem to regard me as unusually fit, but in the pensioners' CTC (Cyclists' Touring Club) group I ride with every week there are eleven octogenarians with two more to qualify in 1996. At 93 the eldest rode regularly until 1994 and ten more of the thirteen still ride. I know of many more in the UK. Survival into the eighties is now unremarkable but is possibly more noticeable amongst cyclists who have a better recovery rate and tend to live longer than non-cyclists.

Luck must play a big part, certainly so in my case. I had a secure childhood despite the 1914-18 war, but in 1918 my father was in hospital suffering from war wounds and my mother was seriously ill with influenza. That epidemic killed more than died as war casualties. My parents survived, so my vital teenage years were spent in a stable working-class family. My father died at 46 and my mother lived to 94.

I became a keen cyclist at a time when in our road there were no cars, and my father owned the only motor-cycle. The road is now lined on both sides with parked cars: the houses have no garages. My first taste of touring was with my father on his motor-cycle and sidecar in 1925. I was 18 and did some of the driving. A year later I did my first cycle tour, in France, with a companion. So was born my love of the open road and the foundation of my cycling experiences.

The next forty years included marriage, four years in the RAF, family and business affairs and very little bicycling. However, in 1962 I took my son to the (UK) Cycle Show and saw the introduction of the Moulton. I bought a Stow-away (a collapsible version) that spent most of its time in the boot (trunk) of the car. This tentative return to cycling was followed by a second-hand ten-speed, rejoining the CTC, and some riding in

the Surrey countryside, avoiding local traffic by carrying the bike on the roof rack.

Retirement came in January 1968 at age 61 and I had an arrangement with my wife that I could take Mondays off for a day's bicycling. One Monday I was looking disconsolately at the rain. My wife said "If you don't go you've had it!" So I went and learned the invaluable lesson that a wet morning is most likely to give way to a fine afternoon. My wife cycled locally and we did a good deal of walking and car touring together, but she didn't take to long-distance cycling, even on a tandem.

Soon I had company on the regular Monday ride, and this small group of like-minded pensioners is still riding every week. The instigator died at age 86 and cycled almost to the last. In his final years he reduced gears and saddle height and raised the handlebars. He was slow uphill. One day as we waited at the



Ron Beams on his recumbent tricycle

top of a hill he arrived grinning broadly. I said "What's the joke, Chater?" He said "I've just been passed by a woman pushing a pram!" (baby-carriage).

In 1969 I drove the "sag wagon" for the International Bicycle Touring Society of America, led by Dr. Clifford Graves, and learned much more about cycling and touring. I also met Dan Henry with his sprung bicycle and silk tubulars (sew-ups). Dan later was a pioneer of recumbents.

By 1977 I had gained experience on tricycles and started building my first recumbent tricycle, which we modified (mark 2) for entry in the first HPV event here in 1980. How we marvelled at the Vectors!

Sadly, my wife died the following year. There followed a period of adjustment to life as a widower, helped by the fellowship of my cycling friends.

Gradually I expanded my cycling interests through membership of the Veteran-Cycle Club, and from the age of 75 to date have cycled twice a week regularly and toured extensively. A catalogue of events will serve no purpose here except to say that I have averaged about 4000 miles annually. I voluntarily gave up motoring in 1993 and did 3500 miles in 1994, all on recumbents.

Regular cycling has, I believe, kept me fit, so here are some personal details. As a child I suffered severely from asthma until about the age of fifteen, but have had no recurrence. As you might expect I have had some illness and accidents but none has left a health or disability problem. A touch of angina causes some breathlessness, particularly in cold weather. I like an argument, and being hard of hearing makes discussion in a busy pub somewhat frustrating!

Walking and gardening have been my only other exercise. I did no racing, am not a fitness fanatic and did no training for past century rides. My appetite is good. I eat anything with plenty of fish, vegetables and fruit. Beer, wine and spirits I enjoy in moderation, and I gave up smoking when I retired. I am told I use too much salt and sugar! At 5'10" I weigh 180 lb with a chest of 44" and a waist of 42". The latter is a burden, but neither that nor my weight varies. I've no interest in dieting, and nothing I do seems to make any difference, so why worry?

The British Medical Association book "Cycling towards Health and Safety" states "... even in the current hostile traffic environment, the benefits gained from regular cycling are likely to outweigh the loss of life through cycling accidents..."

To sum up, cycle regularly in company, cultivate an absorbing interest and you stand a good chance of riding as an octogenarian.

Recumbent tricycles have been an obsession of mine for many years, and I hope to tell you about my experiences with them in my next article.

W. R. E. "Ron" Beams

*Coral Gables, Park Lawn Road,
Weybridge, Surrey KT123 9EU, UK*

Phone from the US: 011 44 1932 844038

*Ron Beams is a well-known member of
the Veteran-Cycle Club and of the British
Human-Powered-Vehicle Club.*

Letters

Is it an EAHPV or an EPV?

After reading the Electric Assist Tri-canter article by J.K. Raine and N.G. Maxey in the fall/winter 1994-5 Human Power (11/4/94/4), I would like to make two comments. I see an article containing detailed engineering data on a electric system but I question the use of the term AHPV in describing this system.

I see a vehicle system with a quite large, heavy motor/battery combination used in continuous operation. It's a system that hardly applies any AHPV principles. An AHPV uses predominately human power for the trip, has a very light assist power source, proper gearing, and intermittent use of the assist. The electric Tri-canter has the characteristic of a motorized vehicle - almost where the human assists the power source. It seems to be closer to a moped, and too far from the elegance of an HPV. It's more apt to be called an EPV.

An often heard complaint of motors on bikes have been they are designed towards replacing human effort, and indeed this has been the philosophy of the past. People do not want to endure a more continuously operated gasoline engine or the excess weight from an electric system. Another complaint centers around the concept, Bigger is Better. Even though the original idea starts with a small power source the tendency is to install a larger system to get more "performance" - a more powerful boost motor to climb hills - or to go faster. The design of the system should reinforce a more miserly consumption of energy. 21st-century thinking requires a more sensitive approach.

The second issue is, if we are designing a system to get people out of their cars, I then have to question the human power capability used (270 watts/.36 HP for 20 minutes). I too originally used the "healthy-human" power curves only to find out later that this represents mostly college and military people (males) and cyclists who are in training - a younger, stronger, and a more in-shape group that does not need nor want assistance. The healthy-human curve also represents a

smaller percentage of the population that, by my observation, is less interested in using HPVs as alternative transportation.

For the paper I gave at the Fourth Scientific Symposium in Yreka I produced an additional curve from a guesstimation I made from observing myself and a cross section of more average people. These are people who are active but not continually working at getting into shape. They also represent a larger percentage of the public, and with a practical vehicle could be potential users of HPVs for alternative transportation. The curve is labeled "Reasonable Humans" (as contrasted from "Animals", which got a good laugh at the symposium). This curve happened to be omitted in error in the printing of the proceeding: it is included here.

You will see that producing 270watts/.36 hp for 20 minutes is way beyond the capabilities of "reasonable

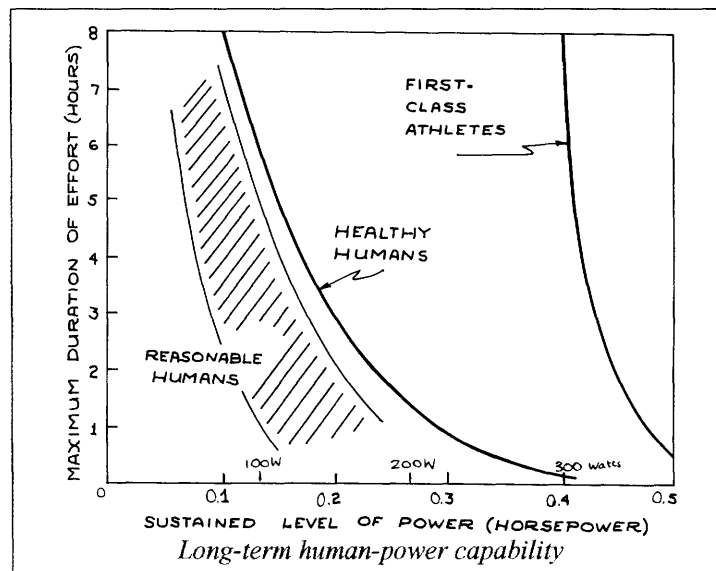

humans". The rider would arrive close to exhaustion (the recovery rates from exhaustion can be 20 hours or more). There is also the return trip to account for. So if we divide the 270 watts/.36 hp by two and further reduce the power demand so that the rider won't get home exhausted, we find we are heading towards the 0.1-hp 75-W capability.

The steepness of the power-capability curves shows that a small increase in power demand can quickly bring the rider towards exhaustion. Laboratory curves show continuous power demand and do not address on-road intermittent demands, but they do indicate the limitation of human power.

The problem of applying an assist for level commuting seems to be almost more difficult to solve than up-hill assist. I have received several letters discussing these issues from IHPVA members who live in the flatter parts of the land. I have some ideas, but from where I live and from the trips I have taken, level-ground assist is not on my immediate agenda.

But here is one approach. I have a Lightning F-40 that is set-up for alternative transportation ie; - touring tires (low incidence of flats) heavy-duty spokes, no wheel disks, sealed bearings, fenders, luggage rack and panniers, and a lighting system for night riding. It weighs in at 40 to 45 lbm/20.3kg (plus an additional 6 lbm/2.7kg for the up-hill assist). It allows me consistently to do 18mph/28.8km/h on flat ground for in the range of 0.1 hp of effort. With a little extra push it will pop up to 20 mph/32 km/h and on slight down grades it will approach

30mph/48km/h. Coasting is a common occurrence. A wonderful feeling is getting it up to speed and stopping pedalling - it continues to coast and very slowly drifts down in speed. It feels as if one is getting something for nothing. Coasting gives the rider a chance to rest. The advantage of this work-rest strategy is mentioned in the Fourth Scientific Symposium by Rick Powell (Arm-Power Performance: Mechanics and Physiology).

To be able to do 20mph/32km/h within the range of 0.1 hp dramatically shows the value of good aerodynamics and little need for assist on flat ground. But more, it is within the range of reasonable human-power demands. Trying to obtain higher speeds not only demands considerably more power (and a much heavier assist system) but also better safety systems, lights, tires, suspension, road conditions etc. Given present conditions and technology, 20mph/32km/h is a good starting point.

Most terrain is seldom dead flat so I could envision a F-40-type vehicle with a tiny power source geared to assist the rider only up slight grades. Because of the repeated instant on/off requirements,

an electric system would be better for the shorter up-grades and distances. Used intermittently, the weight and power requirements (also demands on the human when assist is not in use) would be in line with the efficiency and elegance that is an HPV and a reflection of the concept of an AHPV.

Another concept is this: set up as a transportation vehicle the F-40 does not do as well in short stop-and-go city riding. It is more of a suburban vehicle - excellent between neighboring towns (and terrific on long trips). To help get it back up to speed from city stop-and-go, a light-weight energy accumulator would be a 21st-century solution.

John G. Tetz

*7 B Mark Lane, Succasunna, N. J. 07876
Phone: 201-584 6481*

AHPVs: a plea for agreement

It is gratifying to see after a dormant period of over six years that a lively discussion on the pros and cons of assisted vehicles has started up in the pages of Human Power and HPV News, and that also a number of new vehicles have and are being built. The World Solar-Car Rally 1994 in Akita, Japan, had a field of 64 "solar bicycles" amongst 70 "solar cars". The first of 200 TWIKes are rolling off the assembly line (the TWIKE is an assisted two-person three-wheeler, brain-child of Future Bike president Ralph Schnyder, originally presented at EXPO 86 in Vancouver); Michael Kutter has finished his first production run of 20 VELOCITY electric bicycles (one of which is being enthusiastically used by me!); and every year several new manufacturers of electric bicycles appear. Swiss motor-vehicle regulations are in the process of being favorably adapted toward electric bicycles and a new class of low-power motor vehicles.

However: there have been no major technical or marketing breakthroughs, no progress whatsoever in "accumulator" type vehicles (a term coined I believe by Peter Sharp for devices meant to store and release on demand the small amounts of energy available from regenerative braking or short downhill runs), and no progress in the development of

practical "ambient energy", i.e. solar or wind vehicles. Also, the lively discussion mentioned consists mainly of people discussing their own fixed ideas on how assisted vehicles should be and finding fault with the ideas of others. I am no exception, but will try to keep an open mind at least for the duration of this letter. It lies in the nature of assisted vehicles that there are endless variations and each one is especially good for some special purpose and none are good for all purposes. Speed records using a mixture of human and stored power are quite uninteresting and even straightforward racing either contains restrictive or peculiar rules or highly subjective scoring systems, all pleasing almost nobody. Assisted vehicles are therefore built to be used, not to be raced.

Fine, many will say, let's forget these bastardized devices and ban them from participating in OUR events. With notable exceptions, so say the electric-car people, the traditional cyclist people, and the purist human-powered people. Unfortunately for the developers of assisted vehicles, not being able to present them at races and events greatly delays their public exposure and acceptance, their further development, sales, and ultimately the clean air amongst other things that we are trying to achieve by developing alternatives to present motor-cars.

The purpose of this letter is therefore a plea to find a mutually satisfying way of presenting assisted vehicles at IHPVA events. It should be satisfying to the long-distance/ low-power, to the short-distance/ high-power, to the electric, to the solar-hydrogen, the gasoline and even the wood-chip Stirling-motor fraternities! And also acceptable to those interested in pure human power for racing and unadulterated exhaust fumes for transportation! So let's try: first there seems to be a consensus that assisted or hybrid records are meaningless and there is no question of introducing unteen new record categories.

The following is to apply only to racing and practical-vehicle-type competitions. Another consensus is that a 50/50% power split seems a good idea. The 50/50% power rule was originally proposed by me as an attempt to define a suitable hybrid power standard. In the

discussion and correspondence these past years this proved to mean something different for every person. My own preference was to allow quite high peak powers for acceleration and hill climbing just as humans also have high peak powers for acceleration (up to 2 kW!). This discussion is rather academic, as momentary motor power levels are just as difficult to define as human power levels. An electric motor rated 200 W can usually release 400 W peak power, for example.

For these reasons, based on a proposal by Peter Sharp, I am for a simpler, unambiguous definition of the power-assisted class and for dropping the difficult power-level definition altogether: there should be a separate IHPVA class for hybrid or power-assisted HPVs. There would be no restrictions within this class except the following four.

1) Every course for this class must be traversed twice, once using the additional power source and once carrying but not using the same additional power source, including batteries or fuel. The vehicles are scored using the average of these two times.

2) The class is subdivided into the following subclasses with priority assigned in the following order: ambient-energy vehicles with power storage (e.g. solar or wind). Zero-emission or electric vehicles. Renewable-energy vehicles (e.g. biomass or home-produced hydrogen). Fossil-fueled vehicles.

3) Vehicles with emissions (i.e. the latter two subclasses) must be used in such a way that other competitors are not subjected to the emissions. Vehicles with excessive emissions may be banned by the organiser.

4) Vehicles must incorporate an appropriate standard of safety and be scrutinised by the organiser before any event. Vehicles deemed unsafe may be banned by the organiser.

Apart from these requirements the event organiser is free to incorporate this class within an IHPVA competition. Note that the requirement of pedalling the vehicles for 50% of the distance without energy storage works against those with powerful motors and heavy batteries. Those which could benefit most from the 50/50 distance procedure are those with lightweight but powerful motors. With present technology, these

are fossil-fueled, loud and polluting and therefore given least priority. These proposals contain nothing about "accumulator" or non-stored ambient-power vehicles. Although these might share much of the technology of the assisted vehicles, they are much more tightly defined subclasses that are with present technology no threat at all to pure HPVs in races and could therefore be easily used within the existing HPV classes. Indeed some national rules expressly allow ambient energy in some cases and "accumulators" in others and Marti Daily has pointed out in a letter that the present IHPVA rules actually allow "accumulators" by implication for non-record activity without anyone ever having tried to exploit this!

"Accumulator-vehicles" are defined as those with energy-storage devices that are completely discharged before any event (this effectively makes the use of lead-acid batteries impossible). Ambient-energy vehicles are for this definition streetworthy solar- or wind-powered vehicles without energy storage except for an optional "accumulator" as above. This definition excludes solar cars which usually have no human-power provision and rely on considerable energy storage. It does allow a few solar panels to provide a bit of power when the sun shines or a cleverly contrived fairing to exploit any wind available. In the right conditions, even quite ordinary fairings allow "sailing" even if it is not always recognised as such. The question really boils down to whether a little "solar sailing" would be permissible as well.

Excesses are avoided by requiring vehicles to be streetworthy and safe. Due to numerous technical difficulties and the unpredictability of the weather at a given time and location, "accumulator" and "ambient-energy" vehicles are at present no threat to pure HPVs and can be allowed to take part in the same races without any further regulation being needed. There is obviously no point in setting up records for human-powered ambient-energy hybrids. Records for ambient-energy vehicles without human power or stored power are interesting and are maintained by other organisations, so there is no need for the IHPVA to be involved here.

I do hope for favorable reactions to the above proposals, which, I believe, could be acceptable to all involved. Please therefore write or fax (fax during Swiss daytime, please!) signalling your approval or not and pointing out things I may have missed. Thanks to all!

*Theo Schmidt, VP
Hybrid Power, VP
Future Bike Ort-
bühlweg 44
CH-3612 Steffis-
burg, Switzerland
Phone/fax:
41-33-37-19-12*

Stirling engines

This is to Human Power and to Izzy Urieli. Thank you for your comment in HP 11/4 regarding my reluctance to accept Stirling engines as possible candidates for AHPVs, as expressed in my paper "bridled assisted HPVs, unbridled chances" in HP 11/2 (spring-summer, 1994).

We all agree that, ideally, an assist must be as compact and efficient as possible. The Stirling engine doesn't seem to qualify for AHPVs, because the smaller engines become, the more important heat conduction becomes in short-circuiting the "hot end" at the absolute temperature T_2 and the "cold end" at temperature T_1 , and the efficiency drops. (It is proportional to the Carnot efficiency given by $(T_1 - T_2)/T_2$, so that any reduction in the temperature difference is penalizing). Incorporating measures to reduce this thermal short-circuit increases bulk and price. Stirling engines are also not easy to start and to control.

If [Izzy Urieli's] group can overcome these difficulties and attain a "2-hup"

THE PEDESPEED.



"The Pedespeed", forerunner of roller blades, as shown in The English Mechanic April 8, 1970

(150-Watt) engine of 2 kg it would be warmly welcomed. I hope that he presents his results at a forthcoming HPV symposium.

*Peter Ernst, Alex Moser Str. 15
CH-2503 Biel-Bienne, Switzerland*

Review

The English Mechanic

GM Design, the business name of Gerry Moore, has reprinted "a selection of designs for velocipedes published by the magazing "The English Mechanic" between 1865 and 1870". There are forty pages of drawings and descriptions of machines that might seem impractical now, but with the materials and techniques available at the time must have been in the forefront of the human-power movement of the period. As you can see from the drawing above, the ideas could be quite advanced. This small paperback book is priced at £3.95 plus postage from GM Design, 66 Angerstein Close, Weeting, Brandon, Suffolk IP270RL, UK.

Book review

The spaceframe Moultons
by Tony Hadland

This is another labor of love by Tony Hadland. He wrote and published "The Moulton bicycle" in 1981, on the original Moultons, and "The Sturmey-Archer story" in 1987. Both contained fascinating and invaluable historical and engineering data that were otherwise out of reach of normal people. Tony Hadland loves his subjects. There are noble biographers who write on topics they loathe, on Hitler and Stalin and the Boston strangler, with creepy fascination and an air of warning "lest we forget". Tony Hadland also wants us not to forget. He wants lessons hard-learned to be remembered, and pioneers who have benefited us all to be acknowledged and given due credit. He succeeds gloriously.

The book starts with a little history on Alex Moulton's family, beginning with a great-grandfather who spent time in the U.S. and made friends with Charles Goodyear. Thus was the connection with the use of rubber as an engineering material established (Alex Moulton was best known for his development of highly successful elastomeric motor-vehicle suspensions when he started to re-invent the bicycle). Then there is a short review of the history of the original Moulton bicycles before Hadland plunges into the story of the development of the latest "spaceframe" Moultons. He does so with a wealth of sketches, drawings and photographs, sometimes omitting no detail, however slight (as my headmaster used to demand when faced with a pupil who had broken the rules). If these details were given for every decision and every component they would become boring. There are just enough examples to illustrate how painstaking and thorough engineering development is. For instance, there is a photo of nine leading-link suspension forks designed and built in the 1976-79 period. Most books about successful inventors bypass such vital information. Biographers make it appear that successful inventions spring fully formed like Zeus from the womb. This book makes ordinary mortals like you and me feel comfortable. Even great designers aren't right first time, and maybe not the ninth time.

The IHPVA appears prominently in many pages, represented especially by Doug Milliken and occasionally Chet Kyle and many other stars. There are chapters on other races, including the RAAM, and on notable tours and trials. There is also an appendix of useful information.

Tony Hadland publishes his own books. I read somewhere that he gave up the effort of finding a willing publisher. I can believe that, having had about a dozen publishers turn down "Bicycling science". Self-publishing means also that he had no editors, no dictators of the semi-colon. Although I have greatly resented many book editors for their meddling ways, I confess that most people need editors. Most people can write neither the president's nor the king's English. Tony Hadland's writing is, however, simple, direct and enjoyable to read. The layout is totally free of "artsiness": he doesn't waste paper with huge margins and complex fonts. He gives one the impression that he's dying to get across information about which he is very enthusiastic, and he's not going to leave stretches of blank paper when these could take another sketch or another paragraph. I like this book, and recommend it heartily.

Dave Wilson

The spaceframe Moultons, by Tony Hadland; £17.95 (about \$29.00) plus £6 postage, airmail for Europe and surface mail elsewhere, or £14 for airmail elsewhere, from 39 Malvern Road, Balsall Common, Coventry CV7 7DU, UK

Book review

Pedalling unknown paths
by Michéle Velthuisen-de Vries

This is the story of a bicycle tour by a couple from the Netherlands, told by the female partner. Only after I had agreed to review the book and received it did I find that the tour was made on two LWB USS (long-wheelbase underseat-steering) recumbent bicycles. That made it much more interesting. However, it turned out that there was not a great deal about the bikes. After they had decided to tour the USA after her graduation, Michéle's husband Nop took the wind out of her sails first by suggesting that they travel by bicycle, and then that they use what to her was a totally new form of bicycle. Nop

had seen a Roulandt recumbent and had become excited, but felt that he could do better. He designed and built the two bikes by an effort that is, alas, only hinted at by his wife. But it was a tribute to recumbency and to Nop's abilities that they traveled 16,000 miles in comfort and without major problems more-or-less straight "off the drawing board", and that they were accepted as bicyclists from overseas, and not "weirdoes". They became very tired on occasion, but there were no tales of pain and numbness and stiffness as there almost inevitably is in a description of a long tour on a "head-firster" bicycle.

The Velthuisen-de Vries took a freighter that dropped them off at Point Comfort, near Victoria, Texas. They went to visit friends in Austin, backtracked to Victoria and then on to Brownsville and along the Mexican border through Las Cruces, Tucson and Yuma and eventually to LA. There they began an enormous loop with many wide zig-zags through Utah and Wyoming, and then more directly to Maine and a more southerly route back to LA.

Michéle writes very well. She paints word pictures and notices details and broad sweeps. At times her account of an inevitably grueling ride is almost like a novel. One is anxious to know how they were treated in the next town. She tells of their reception in the US, warts and all. They received a great deal of generous hospitality, and a share of near-murderous red-necks telling them to "get the f*** off the road". There is more detail on the early stages of the trip. By the time they reached New England on p. 208 they must have been getting weary, for many states receive just a cursory mention, and on the southern return loop to California some states are not mentioned at all. But that's OK: the book would be overly long if the same detail were covered everywhere. They finish triumphantly, visiting Marc Duisenberg's "Just Recumbents" store in Palo Alto, going to a talk by Steve Roberts, and hosting them all at supper where the talk was about recumbents and long-distance riding. It's a good read.

Dave Wilson

Published 1995 by The Book Guild Ltd., 25 High Street, Lewes, Sussex, UK, price not known.

Technical note The Daedalus HPA- why shaft drive?

Jean-Joseph Cote

Bicycles have successfully been using chain-drive for about a century with great success. The modern roller chain provides impressively high power efficiency, and derailleurs allow a fairly simple and straightforward manner of gear shifting. Yet the three Daedalus human-powered aircraft, which currently hold all of the world records for distance and endurance, used a shaft-drive design. In light of the presumed lower efficiency, what were the considerations involved in this design decision?

The drive train for Daedalus was designed by Bob Parks. Bob had worked on the Chrysalis HPA several years earlier, and had closely followed other HPA projects, and was well aware of the issues involved. One of the major differences between a bicycle and an airplane is the axis of rotation of the propulsion device. On a bicycle, the driven object is a wheel that has an axis parallel to the pedal cranks. A chain-drive works very well for this. On an airplane, however, the propeller must rotate on an axis perpendicular to the cranks. Because it is not practical to change the orientation of the pilot-motor, the drive train must change the orientation of the power. There are a number of solutions to this problem, including electric or hydraulic drive trains, that I have never heard of anyone using in an HPA. The most common solution among reasonably successful HPAs has been the use of a flexible chain.

These chains (from Winfred Berg) consist of two steel cables with molded plastic "buttons" between them, and they fit standard bicycle chainrings. The classic solution is to have the flex-chain loop around the bottom of the chainring and twist 90 degrees on its way up to the upper boom of the aircraft, where it loops around another chainring that is connected to the propeller shaft. There are usually several idler pulleys and/or tensioners between these chainrings. The main problem with flex-chain is that it has a propensity to jump off of the chainrings from time to time. For a "recreational" HPA that is going to fly only around the runways at an airport, this isn't a major problem; if the chain jumps, that's the end of the flight. After gliding

to a landing, the chain can be put back on the rings and the pilot is ready to go. The situation is quite different for an airplane that is trying to fly for four or more hours over water. Reliability is the primary concern, and that was the main reason for deciding on shaft-drive. The design chosen had one pair of bevel gears at the cranks, to turn a vertical carbon-fiber drive shaft, and a second pair at the upper boom to turn the prop shaft. The first pair of gears had a 3:2 ratio, and the second pair was 1:1, so the propeller turned at 1.5 times the rate of the pedals (nominally 120 rpm for an assumed 80 rpm cadence).

Efficiency, weight, and gear shifting are also concerns when designing a transmission, and a shaft-drive was adequate for the requirements of Daedalus. Though bevel gears have some frictional losses, these were minimized by choosing the components carefully. The basis of comparison is not the marvelous bicycle roller chain, but rather the flex-chain, which is probably not nearly as good, since the buttons slide on the gear teeth, and there is energy lost to the bending and unbending of the cables. The shaft-drive weight was reduced by custom machining. Hardened-steel bevel gears were chosen, and a substantial amount of material was removed from each. These gears were designed to be mounted on steel shafts with keys, but to save weight Daedalus used aluminum shafts, with a 10 mil (if I remember correctly) interference fit. Pressing a gear onto a shaft required cooling the shaft in liquid nitrogen and heating the gear in oil to just below the point where the hardness would be affected. Even so, assembly was only barely possible using the biggest arbor press in the MIT Aero-Astro shop.

A human-powered aircraft differs from a bicycle in a few other ways, among them the fact that the power and cadence of the pilot are limited to a narrow range: there can be no sprinting the airplane! This has some impact on the design of a shaft-drive transmission. The shafts can be made very light because the peak loads will not be very high (and if they are made from carbon fiber, they can be custom designed to take torsional loads well, but not waste weight on bending or tension strength, etc.). It is not necessary to have wide-range gearing such as would be required to climb hills on a bicycle. Most HPAs have a fixed

gear ratio, but the Daedalus planes had variable-pitch propellers that provided a function exactly analogous to gear shifting. The range was limited and was continuous instead of having discrete ratios. A bicycle shift lever mounted on a fuselage tube in front of the pilot controlled a cable that moved a ring at the base of the prop blades that adjusted the angle with which they "bit into" the air. Typically the propeller would be set "flat" for take-off, and as the speed of the plane increased, the pilot could increase the pitch. Once at cruise speed, the pitch would remain the same until landing.

Though the shaft-drive transmission for Daedalus worked very well, it would be hard to justify the effort of building such a transmission for other purposes. Bob Parks, who designed and built the six gearboxes for the project (as well as numerous other parts of the planes), is an extremely talented engineer and a very good machinist. There was some very delicate shimming work required to perfectly align the gears in the gearbox housings in order to maximize efficiency and minimize wear, and more delicate alignment work when the gearboxes were initially installed. As with everything on these airplanes, some of the gearbox components were designed to be marginal, and on the prototype airplane, the Light Eagle, there were problems with broken gearbox shafts (I had to remove and install one of the gearboxes several times to repair them). Part of the problem arose from the fact that the bevel gears and the transmission were designed to transmit power in only one direction, and some of the parts could not take reverse loads (the helical teeth on the bevel gears were a factor here). If the pilot stopped pedalling with the airplane in motion, the wind on the propeller would load up the shafts the wrong way, and the next time the pedals turned, a telltale grinding sound would indicate that another gearbox overhaul was in order. So although a light and efficient transmission could be built for this special-purpose vehicle, it would be difficult to do nearly as well for a more general-purpose vehicle such as a bicycle.

Jean-Joseph Cote

<71163.3347@compuserve.com>

**Correction to table in "The unfair advantage?" by Martin Staubach (HP
11/1/94/16)**

(Through an error of mine, some entries in this table were omitted. My apologies to Martin and to our readers. Here is the complete table, which I hope is self-explanatory. Dave Wilson)

**VEHICLE DRAGxAREA (Cd.A)
(measured by coasting downhill)**

No.	Vehicle description	Cd.A (m ²)	Improvement vs.		
			St'd bike	SWB recumbent	
1	Standard bike, TV		0.60	0	-71%
2	Racing bike, RV, hands on brake levers	0.49	18	-40	
3	Racing bike, RV, downhill racing position	0.42	30	-20	
4	Racing bike, RV, RS, triathlon handle bars	0.27	55	23	
5	LWB recumbent, TV, LHB, BBS -200	0.49	18	-40	
6	LWB recumbent, TV, LHB, BBS -150, Front - Zzipper	0.36	40	-3	
7	SWB recumbent, TV, LHB, BBS +60	0.35	42	0	
8	SWB recumbent, TV, LHB, BBS +60, one hand on body	0.32	47	9	
9	SWB recumbent, TV, LHB, BBS +60, aerobag	0.29	52	17	
10	SWB recumbent TV, HHB, BBS +60	0.28	53	20	
11	SWB recumbent, TV, HHB, BBS +60, aerobag	0.29	52	17	
12	SWB recumbent, RV, RS, BBS +60	0.25	58	29	
13	SWB recumbent, CANARD full fairing	0.13	78	63	
14	Tricycle KWADRAD II, TV, 2 fr. wheels, 1 r. wheel, BBS 0	0.43	28	-23	
15	LEITRA tricycle	0.24	60	31	

Comparison with wind-tunnel tests (Tour magazine 3/90), Kukuk, Miller:

16	Racing bike, RV, RS; hands on brake levers, Tour 3/90	0.49	19	-39	
17	Racing bike, RV, RS, downhill racing position, Tour 3/90	0.40	33	-15	
18	Racing bike, RV, RS, triathlon handle bars, Tour 3/90	0.37	38	-6	
19	Racing bike, downhill racing position, Kukuk 1982	0.42	30	-20	
20	Racing bike, RV, clothing?, downhill racing pos'n, Miller '82	0.39	34	-13	

Explanations

All measurements were made in street clothing (jeans, sweater, no jacket), except those with the comment "RS" (racing suit). The test rider was 1.80m, 5'11". Other notations have these meanings.

TV	<i>Touring version (mudguards, carrier, light)</i>
RV	<i>Racing version (bike "naked")</i>
BBS	<i>Bottom bracket height above seat in mm, neg. figures = BB under seat</i>
LHB	<i>Low handlebars under the seat ("USS")</i>
HHB	<i>High handlebars ("ASS")</i>
RS	<i>Racing suit</i>

Martin Staubach 1993

Editorials

Following the surf

Avid readers of these editorials (I'm using "readers" in the plural, although there may be only one) will have noticed that I read *The Economist*. Perhaps "scan" would be a better word: there's too much to do more than run one's eyes over the headlines and the photographs and the wonderful cartoons. Someone on the staff seems to have an interest in sports in which normal staid readers of this upper-crust magazine would not indulge. A recent issue had a full-page article on the plight of professional bicycle racers. The writer painted a sympathetic picture of superb athletes in the most grueling sport in the world going from one cheap hotel to another, chasing after tiny purses, frequently injured, without much physical or emotional support, and usually retiring in their twenties without prospects of a succeeding career.

The issue of April 15 had a less-harrowing story about the world champion Olympic surfer, Kelly Slater, whose prize money in 1994 was \$78,425. The tenth-ranked pro won \$23,000. Even the surfing life can be dreary, it was claimed by lower-ranked professionals. And whereas bicycle racing is a spectator sport in a few countries, surfing is not except for a few aficionados.

There are some similarities to the world of HPV racing, which is also not a spectator sport. Maybe the surfers' proposed solution could work for HPVs.

The Association of Surfing Professionals has persuaded a soft-drink company to become "the sport's umbrella sponsor, providing the . . . money needed to create a worthwhile program. Compared with the golf and tennis professional tours, \$1.68m spread over three years is small change, but to the ASP it is a windfall that it can use to bring the sport into the mainstream. . . The ASP's visionaries dream about each event being filmed and shown later to a global television audience in programs packed with commercials".

I think this concept is worth a try.

The wheel extended

Another journal that I scan fairly regularly is "the wheel extended" (sic), "A Toyota quarterly review". Is it a sign of the times or an outlook of a

responsible automobile company that this magazine has always been refreshingly free of glossy photographs of cars on golden beaches and fields of flowers? It is often devoted to town planning in which car-free areas are espoused.

The latest issue, no. 90, is entirely devoted to NMT (non-motorized transport). Here are some quotations. "NMT covers quite a wide concept that includes travel on foot. There is a similar term, non-motorized vehicles (NMVs) which is restricted to horse-drawn vehicles, rickshaws, pedal cycles, and pedal cycles adapted to carry additional people and luggage. . ."

"We concluded and reported to the World Bank that government policy was the most influential factor in determining the ownership and use of NMVs".

"For instance, some regions offer people who cycle to work a cash incentive equal to the price of a bus pass. Others have increased taxes on motorcycles."

"Central governments could contribute in areas of pricing and provide subsidies for local governments to construct bicycle facilities."

"NMT should substitute for motorized transport wherever possible."

"Rickshaws account for 70--80% of all traffic in old Dacca, Bangladesh, so there is a lot of pressure to reduce their number. . . . I found it was very difficult to change their attitude on this point."

"In Japan, bicycles have been largely ignored as a form of urban transport. There are, however, close to 70-million bicycles in Japan; in other words, we have more bicycles than cars. . . . I believe . . . that the use of cars should be restricted to a certain extent."

"Due to our excessive dependence on cars, we have created an urban environment where the advantages of pedal cycles cannot be utilized, Japan being a typical example."

"An analysis of productive passenger capacities of different types of NMVs and MVs, however, indicates that bicycles and other types of NMVs are more efficient and occupy less road space than single- or multiple-occupant automobiles and single-occupant motorcycles. In fact, all NMV types outperform single-occupant automobiles, which have the lowest productive passenger capacities among all modes. Bicycles, the most efficient of all NMVs, also perform better than taxis and multiple-

occupant automobiles (up to four people)."

Wouldn't you agree that these are remarkably responsible and welcome statements from one of the world's largest automakers'?

Publication frequency

Most members of the IHPVA do not go to race meetings or symposia: they join principally to receive the publications. When these don't arrive as regularly as scheduled they feel short-changed. The IHPVA published three types of publications, two of which, HPV News and Human Power, are included with the subscriptions, and occasional special works such as symposium proceedings. HPV News recently went on an almost-monthly schedule, a Herculean effort that I hope Len Brunkalla and his volunteers can keep up. Human Power is apparently on a more-leisurely schedule of one issue per quarter. This issue is late.

Along with my apologies I'd like to explain the reasons for the lateness. You've heard most of them before. First, this is a volunteer operation. A membership of around two thousand is hardly enough to pay for the printing and postage on the publications. I do all the editing and layout myself and send the almost-camera-ready material to Marti Daily who, besides having far too much to do as IHPVA president, manages other volunteers to get the publications out. Second, a month ago I bought myself a super new computer partly to be able to put out Human Power more speedily. Unfortunately none of the huge supply of fonts that I purchased matched exactly those with which I'd laid out the six-or-so pieces already received. It takes a surprisingly long time to get a multipage article to fit well in the space, and I found pages spilling over into orphaned lonely lines on unavailable sheets - a near-disaster. Third, and most important, many promised **pieces haven't arrived**. As I wrote to one disgruntled member, I don't feel that I can write any more of your technical journal than I already do without getting more complaints. I am very grateful for the high-quality papers, reports and letters that come in: please send more!

Dave Wilson

**International Human
Powered Vehicle
Association**

P.O. Box 51255
Indianapolis, Indiana 46251-0255
U.S.A.
(317) 876-9478